



# WQ

## WQ污水污物潜水电泵 SUBMERSIBLE ELECTRIC PUMP FOR SEWAGE AND SEWAGE



Add:浙江省台州市温岭市泽国镇西城路689号  
No. 689 Xicheng Road, Zeguo Town, Wenling City, Taizhou City, Zhejiang Province, China  
全国统一服务热线:4008-603-757

股票简称:大元泵业  
股票代码:603757

泵与系统解决方案提供商  
PUMP AND SYSTEM SOLUTION PROVIDER

LAIKO® 雷客

# WQ污水污物潜水电泵

SUBMERSIBLE ELECTRIC PUMP FOR SEWAGE AND SEWAGE

泵与系统解决方案提供商  
PUMP AND SYSTEM SOLUTION PROVIDER



懂水 更懂节能

Superior in Pump, Superior in Energy-Saving.

## 节能泵的研发与制造，泵与系统解决方案提供商

# LAIKO® 雷客

大元泵业旗下品牌 | 专注于节能泵研发与制造  
股票简称:大元泵业 股票代码:603757



## LAIKO 浙江雷客泵业有限公司

Laiko Pump (Zhejiang) Co., Ltd.

浙江雷客泵业有限公司是浙江大元泵业股份有限公司(股票代码:603757)旗下品牌,成立背景源于大元泵业超过34年的深厚行业经验与技术积累,在泵领域内拥有全面的产品线和领先的制造技术。专注于节能泵的研发与制造。

雷客泵业的应用领域涵盖了建筑领域、市政领域以及工业领域。拥有立式多级泵、立式管道泵、卧式多级泵、冷热水循环管道泵、单级离心泵、标准离心泵、不锈钢卧式单级离心泵、潜污泵、浸入式多级离心泵等产品线。并在国内建立了广泛的办事处网络,覆盖研发、生产、销售的完整链条,产品远销欧美亚多个国家和地区。

标准的研发、生产、销售和服务体系,奠定了雷客泵业的核心竞争力和可持续发展空间。可靠的产品品质,贴心的售后服务,为雷客赢得了广泛的美誉。

我们保持锐意进取,始终坚持科技创新理念,为我们的客户提供更节能高效的解决方案与服务!

## 浙江雷客泵业有限公司

是浙江大元泵业股份有限公司(股票代码:603757)旗下品牌,注册资金8000万,与新沪同为大元子公司,总部位于浙江温岭。拥有超34年的实力积淀,联盟国内顶级水泵研发、生产、销售、技术团队,综合实力位居行业前列。母公司大元泵业是泵产品国家标准、行业标准的起草单位,是国家认定、授予的“高新技术企业”、“省级企业技术中心”大元旗下自主品牌(“大元”牌、“雷客”牌、“新沪”牌、“SHINHOO”)产品业已通过CE、GS、TUV、ROHS等多项质量和产品认证,销售服务网点遍布全国达10000余家,并出口东南亚、欧洲、中东和南美等近150个国家和地区。

使命——聚焦高效节能泵解决方案  
愿景——为泵行业节能革新注入新活力  
价值观——以人为本、精益求精



## 专注专业 绿色创新 品质至上 合作共赢

雷客泵业全国主要城市都设立了办事处,专业、高效的办事处服务团队,从咨询、购买、售后、维护等各个环节,全程提供高效、专业、及时、贴心的服务。秉持“全心全意,客户至上”的精神,快速响应需求,为客户提供精准的产品推荐与解决方案,提供更具针对性的服务,全方位全周期的提供无忧服务。



中国·浙江·温岭



绿色智慧工厂

GREEN SMART FACTORY

占地近200亩 投资10亿 年产700万台

全流程智能化、自动化、精准检测包装系统、智能物流仓储、国家CNAS认证测试实验室、绿色环保智能标杆工厂



## 科技赋能、品质护航，引领泵业绿色智能新时代

大元泵业集团携手子公司雷客泵业重要战略布局，占地近200亩、总投资10亿元的现代化生产基地，规划年产700万台水泵。生产全流程智能化体系：从智能自动化产线、精准检测包装系统，到智能物流仓储，全方位提升生产效率与品质稳定性；更配备国家CNAS认证测试实验室，以国际标准严控产品质量。同时，通过太阳能覆盖、环保设备应用践行绿色发展理念，打造绿色智能标杆工厂，以科技创新为驱动、以卓越品质为根基，引领泵业行业迈向绿色智造新时代。



## 技术创新 专利护航

346

境内专利

29

发明专利

242

新型实用专利

75

外观专利

6

境外专利

拥有研发人员177名+专利超352项的实力积淀

产品荣获“浙江名牌产品”、“浙江出口名牌”等荣誉

产品远销欧美亚多个国家和地区，综合实力位居行业前列

公司通过多年持续的研发投入，形成了较为明显的技术创新优势



# WQ污水污物潜水电泵

双流道设计 | 高效排污 | 防堵抗磨 | 经久耐用



## 技术参数/TECHNICAL DATA

结构: 除常规污水泵结构, 可选择切割型或者搅匀型。

Structure: In addition to conventional sewage pump structures, cutting or mixing types can be selected.

流量范围Flow range: 7~2800m<sup>3</sup>/h 扬程范围Head range: 7~80m 功率范围Power range: 0.75~250kW

# WQ

SUBMERSIBLE ELECTRIC PUMP  
FOR SEWAGE AND WASTE

## 污水污物潜水电泵

### 应用领域 / APPLICATION FIELD

生活污水	domestic Sewage
建筑/市政污水排放	Construction/Municipal Sewage Discharge
企业污水处理及循环水输送	Enterprise Sewage Treatment and Circulating Water Transportation
厂矿企业的渣浆液抽送	Pumping of Slag Slurry from Factories and Mining Enterprises
养殖业抽送	Livestock Pumping

特殊电缆制作工艺,可完全防止电缆表皮损伤时或者电缆前端浸入水时,水通过线与线之间细小的缝隙浸入电机内部;专门设计的潜水电机,IPX8防护,F级绝缘允许温升高,而潜水冷却效果好,实际温升低,电机绝缘寿命长,可以保证电机异常情况下能自动切断电源;采用双端面机械密封,外配骨架油封,安装机械密封处油腔内特殊设计,油面低下时也能使机械密封足以润滑,延长了密封使用寿命,使密封性能更可靠,有效保证了产品的安全连续运行;叶轮采用封闭式及开放式形状的双流道设计,平衡性好,运行平稳,振动小,增加了产品的使用寿命。流道通过能力强,实测效率高于国家标准,节能降耗;

多种材质可选,可适用于各种介质工况。

电源: 50Hz, 三相380V

介质温度液体状态下 $\leq 40^{\circ}\text{C}$ ,输送介质的固体物的容积比 $< 2\%$ ,介质密度 $< 1200\text{kg}/\text{m}^3$

工作时,最低液不得低于电机的 $2/3$

介质中固体物的直径不大于许可通过的最大固体直径

Special cable manufacturing process can completely prevent water from entering the motor through small gaps between wires when the cable skin is damaged or when the front end of the cable is immersed in water;Specially designed submersible motor, IPX8 protection, F-class insulation allows for temperature rise, while the submersible cooling effect is good, the actual temperature rise is low, the motor insulation life is long, and it can ensure that the motor can automatically cut off the power supply in case of abnormal conditions;

Adopting a dual end mechanical seal and an external skeleton oil seal, the oil chamber at the installation of the mechanical seal is specially designed to provide sufficient lubrication even when the oil level is low, extending the service life of the seal and making its sealing performance more reliable, effectively ensuring the safe and continuous operation of the product;The impeller adopts a dual channel design with closed and open shapes, which has good balance, smooth operation, low vibration, and increases the service life of the product. The flow channel has strong ability to pass through, and the measured efficiency is higher than the national standard, saving energy and reducing consumption;

Multiple materials are available, suitable for various media working conditions.

Power supply: 50Hz, three-phase 380V

The temperature of the medium is  $\leq 40^{\circ}\text{C}$  in liquid state, the volume ratio of solid material in the conveying medium is  $< 2\%$ , and the density of the medium is  $< 1200\text{kg}/\text{m}^3$

During operation, the minimum liquid level should not be less than  $2/3$  of the motor's capacity

The diameter of solid objects in the medium shall not exceed the maximum allowable solid diameter

产品概述 Product Overview

WQ系列污水污物潜水电泵具有如下特点:

The WQ series submersible sewage pump has the following characteristics:

1、特殊电缆制作工艺,可完全防止电缆表皮损伤时或者电缆前端浸入水时,水通过线与线之间细小的缝隙浸入电机内部。

1. Special cable manufacturing process can completely prevent water from seeping into the motor through the tiny gaps between wires when the cable sheath is damaged or the cable end is immersed in water.



2、专门设计的潜水电机, IPX8防护, F级绝缘允许温升高, 而潜水冷却效果好, 实际温升低, 电机绝缘寿命长, 可以保证电机异常情况下能自动切断电源。

2. A specially designed submersible motor with IPX8 protection and Level F insulation. It allows a high temperature rise, and due to the good cooling effect when submerged in water, the actual temperature rise is low, which extends the insulation life of the motor. It can ensure that the power supply is automatically cut off in case of motor abnormalities.



3、采用双端面机械密封, 外配骨架油封, 安装机械密封处油腔内特殊设计, 油面低下时也能使机械密封足以润滑, 延长了密封使用寿命, 使密封性能更可靠, 有效保证了产品的安全连续运行。

3. It adopts a double-end mechanical seal with an external framework oil seal. There is a special design in the oil chamber where the mechanical seal is installed. Even when the oil level is low, the mechanical seal can still be sufficiently lubricated, which extends the service life of the seal, makes the sealing performance more reliable, and effectively ensures the safe and continuous operation of the product.



4、叶轮采用封闭式及开放式形状的双流道设计, 因对称流道, 平衡性好, 运行平稳, 振动小, 增加了产品的使用寿命。流道通过能力强, 实测效率高于国家标准, 节能降耗。

4. The impeller adopts a double-flow passage design in both closed and open shapes. Due to the symmetrical flow passages, it has good balance, operates stably, generates less vibration, and increases the service life of the product. The flow passages have strong passing ability, and the measured efficiency is higher than the national standard, which helps to save energy and reduce consumption.



型号说明 Model Description

WQ D 65 - 15 - 5.5 | A | C / 2

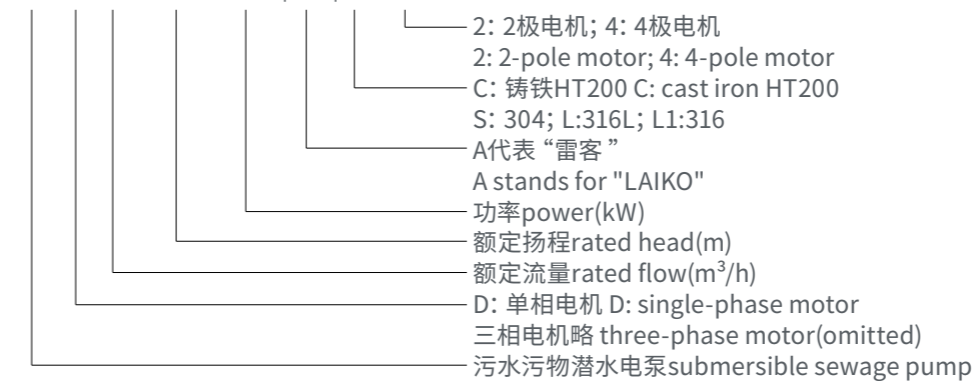

WQ D 65 - 15 - 5.5 / QG | A | C / 2

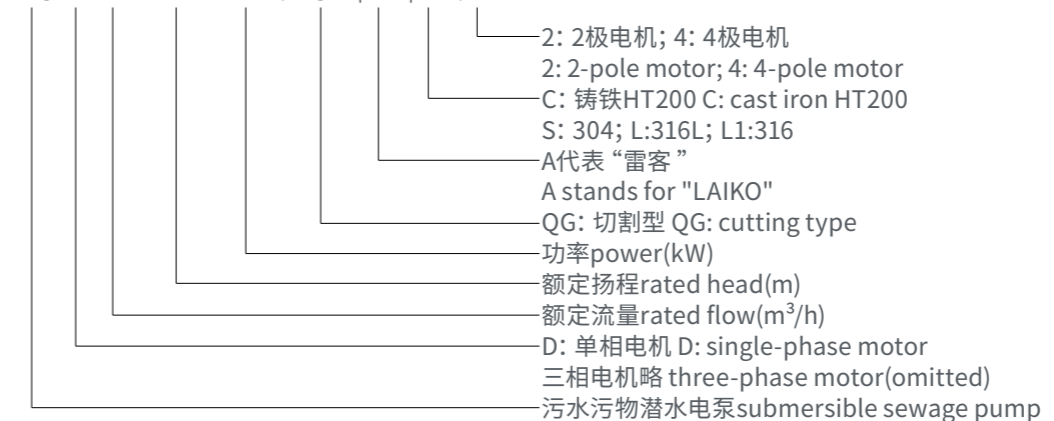

WQ D 65 - 15 - 5.5 / JY | A | C / 2

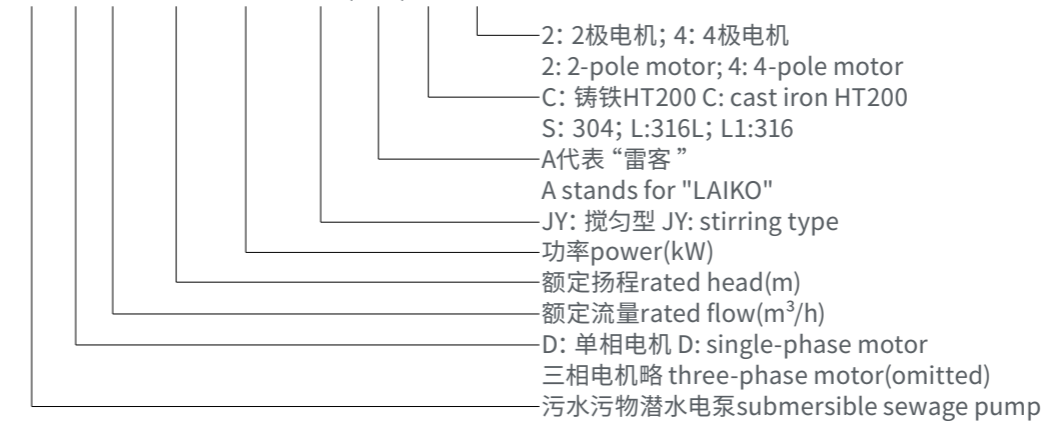

潜水排污泵自耦装置的作用 The Function of The Self-coupling Device for Submersible Sewage Pump

- 1、在水泵发生故障时,可以通过自动耦合装置的滑轨提升到介质外维修,方便操作。
  - 2、自动耦合装置本身的自耦密封和自动吻合,可以使水泵和管道接口快速连接密封。
  - 3、潜水排污泵水质差,安装环境差,自动耦合装置可以解决水下安装的问题,省时省力。
1. When the pump malfunctions, it can be lifted out of the medium along the slide rails of the automatic coupling device for maintenance, which facilitates the operation.
  2. The self-coupling sealing and automatic engagement function of the automatic coupling device enable the rapid connection and sealing between the pump and the pipeline interface.
  3. Submersible sewage pumps are used in poor water quality and harsh installation environments. The automatic coupling device can solve the problem of underwater installation, saving time and effort.



固定式自动耦合安装图 Fixed Automatic Coupling Installation Diagram

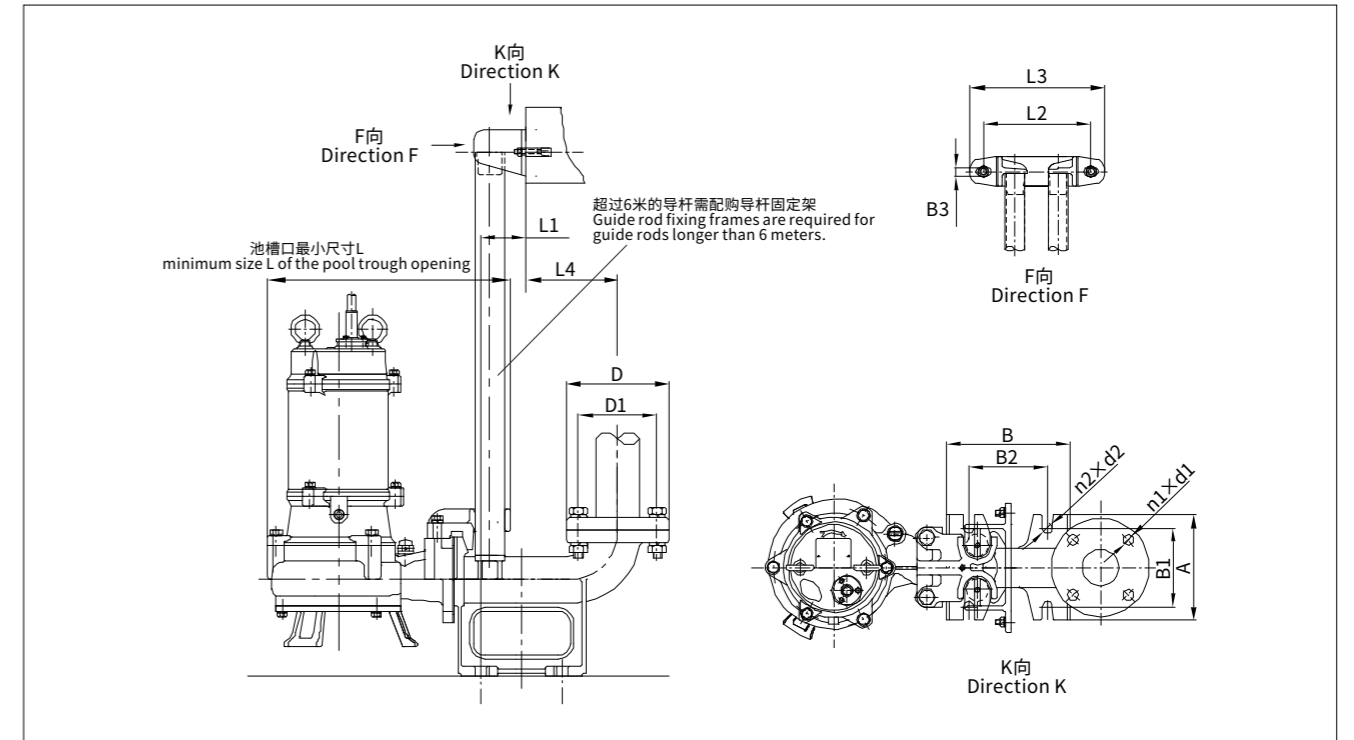

移动式安装图 Mobile Installation Diagram

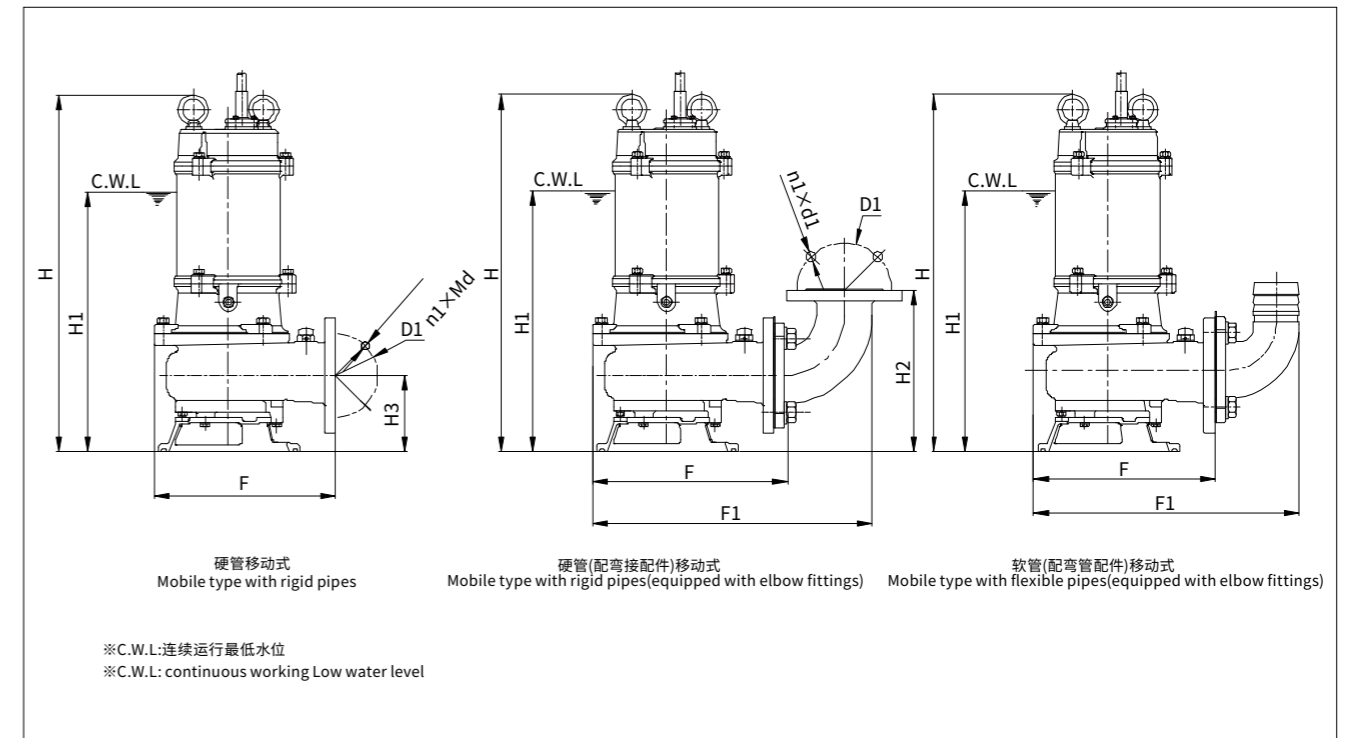

耦合 Coupling



耦合安装尺寸 Coupling Installation Dimensions

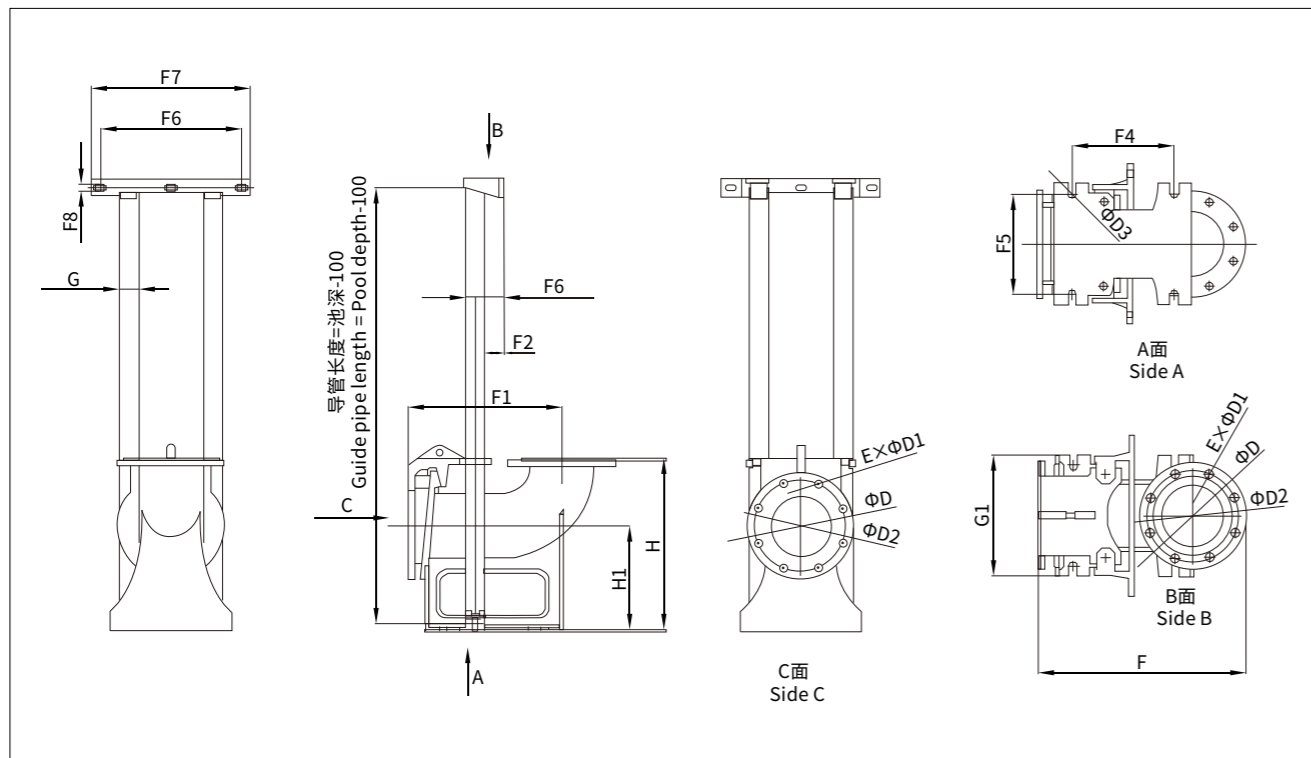

铸铁耦合尺寸 Cast Iron Coupling Dimensions

型号 Model	D (mm)	D1(mm) (6/10)	D2 (mm)	D3 (mm)	E (6/10)	F (mm)	F1 (mm)	F2 (mm)	F3 (mm)	F4 (mm)	F5 (mm)	F6 (mm)	F7 (mm)	F8 (mm)	G (外径*壁厚) (outer diameter*wall thickness)	G1 (mm)	H (mm)	H1 (mm)
DN50	149	14/无 14/none	110	16	4/无 4/none	216	225	148.5	61	164	138	213.5	258	12	32*2.5	163	211	128
DN65	163	14/18	130	16	4/4	242	245	159	64	185	172	235	280	14	32*2.5	202	243	150
DN80	190	18/18	150	20	4/8	235	260	160	72	155	215	266	321	14	48*3	257	306	183
DN100	212	18/18	170	20	4/8	262	298	193	73	176	262	308	368	14	48*3	293	348	225
DN150	285	18/22	225	22	8/8	405	480	291	82	300	285	250	388	13	48*3	360	485	300
DN200	330	18/22	280	25	8/8	446	518	325	82	340	298	250	388	14	48*3	397	555	324
DN250	395	18/22	335	26	12/12	555	608	396	82	428	360	250	388	14	48*3	455	667	345
DN300	450	22/22	395	26	12/12	570	617	394	111	410	410	305	480	15	58*3	550	738	397
DN350	505	22/22	460	26	12/16	615	666	433	113	402	420	318	500	15	58*3	580	858	488
DN400	565	22/26	515	26	16/16	680	714	478	113	510	490	318	500	15	58*3	627	958	562
DN500	675	无/26 none/26	620	28	无/20 none/20	752	817	564	116	550	570	658	748	20	76*4	732	1158	652

注: D1/E分别对应6bar/10bar的最大工作压力。  
Note: D1 and E correspond to the maximum working pressures of 6 bar and 10 bar respectively.

不锈钢耦合尺寸 Stainless Steel Coupling Dimensions

型号 Model	D (mm)	D1 (mm)	D2 (mm)	D3 (mm)	E (6/10)	F (mm)	F1 (mm)	F2 (mm)	F3 (mm)	F4 (mm)	F5 (mm)	F6 (mm)	F7 (mm)	F8 (mm)	G (外径*壁厚) (outer diameter*wall thickness)	G1 (mm)	H (mm)	H1 (mm)
DN50	140	14	110	16	4	268	198	124	73	117	113	182	217	13	32*2.5	130	210	133
DN65	160	14	130	16	4	293	213	128	77	135	130	215	255	13	32*2.5	158	245	148
DN80	190	18	150	18	4	344	249	146	99	160	155	265	315	14	48*3	185	280	165
DN100	210	18	170	20	4	388	283	166	114	192	160	305	355	14	48*3	208	330	195
DN150	265	18	225	20	8	518	386	219	94	255	255	350	392	14	48*3	300	428	262
DN200	320	18	280	20	8	595	435	291	98	303	300	400	446	14	48*3	360	520	300
DN250	375	18	335	26	12	703	515	325	130	364	364	243	436	14	60*3	400	547	290
DN300	450	22	400	32	12	848	623	396	127	448	437	290	520	14	60*3	480	656	350
DN350	505	22	460	22	16	836	583	452	127	600	600	164	380	14	60*3	650	969	430

结构简图 Structure Diagram

WQ型污水污物潜水电泵  
WQ-type submersible sewage pump  
2极电机污水泵截面图  
2-pole motor submersible sewage pump sectional view

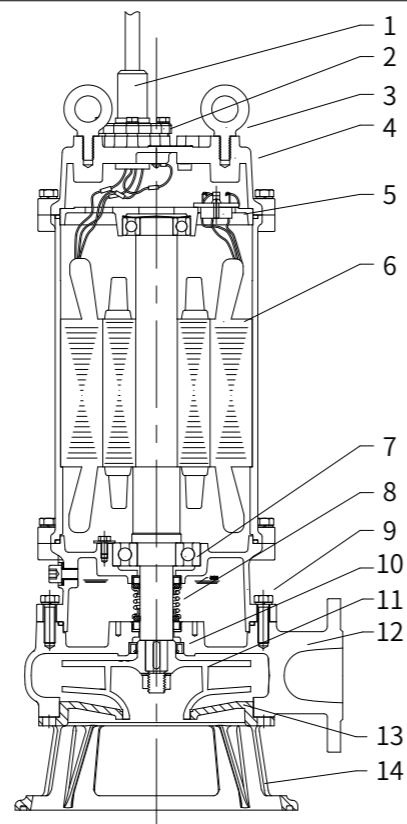

序号 NO.	零件名称 Parts	材料 Material	GB	AISI/ASTM
1	电缆 Cable	/	/	/
2	电缆压盖 Cable gland	/	/	/
3	吊环螺栓 Lifting eye bolt	/	/	/
4	上端盖 Upper end cover	铸铁 Cast iron	GB/T 9439-HT200	ASTM25B
5	热保护器 Thermal protector	/	/	/
6	电机 Motor	/	/	/
7	轴承 Bearing	/	/	/
8	机械密封 Mechanical seal	/	/	/
9	下端盖 Lower end cover	铸铁 Cast iron	GB/T 9439-HT200	ASTM25B
10	骨架油封 Skeleton oil seal	丁腈橡胶 NBR	/	/
11	叶轮 Impeller	铸铁 Cast iron	GB/T 9439-HT200	ASTM25B
12	泵体 Pump body	铸铁 Cast iron	GB/T 9439-HT200	ASTM25B
13	进水口盖 Inlet port cover	铸铁 Cast iron	GB/T 9439-HT200	ASTM25B
14	进水口底座 Inlet port base	铸铁 Cast iron	GB/T 9439-HT200	ASTM25B

结构简图 Structure Diagram

WQ(QG)型污水污物潜水电泵  
WQ(QG)-type submersible sewage pump  
4极电机污水泵截面图  
4-pole motor submersible sewage pump sectional view

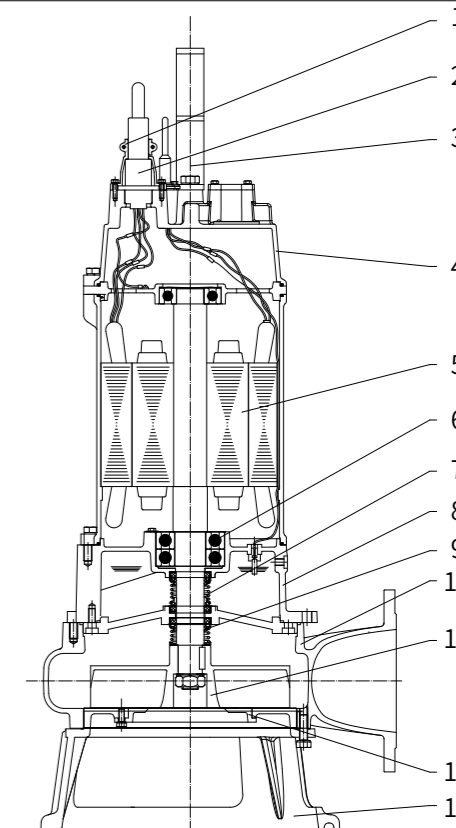

序号 NO.	零件名称 Parts	材料 Material	GB	AISI/ASTM
1	电缆压盖 Cable gland	铸铁 Cast iron	GB/T 9439-HT200	ASTM25B
2	电缆 Cable	/	/	/
3	吊环螺栓 Lifting eye bolt	/	/	/
4	上端盖 Upper end cover	铸铁 Cast iron	GB/T 9439-HT200	ASTM25B
5	电机 Motor	/	/	/
6	轴承 Bearing	/	/	/
7	机械密封 Mechanical seal	/	/	/
8	下端盖 Lower end cover	铸铁 Cast iron	GB/T 9439-HT200	ASTM25B
9	单端面机械密封 Single end face mechanical seal	/	/	/
10	泵体 Pump body	铸铁 Cast iron	GB/T9439-HT200	ASTM25B
11	叶轮 Impeller	铸铁 Cast iron	GB/T 9439-HT200	ASTM25B
12	刀盘 Cutterhead	铸铁 Cast iron	GB/T 3077-20CrNiMo	ASTM8620
13	底座 Base	铸铁 Cast iron	GB/T9439-HT200	ASTM25B

## 结构简图 Structure Diagram

WQ(S)型污水污物潜水电泵  
WQ(S)-type submersible sewage pump  
2极电机污水泵截面图  
2-pole motor submersible sewage pump sectional view

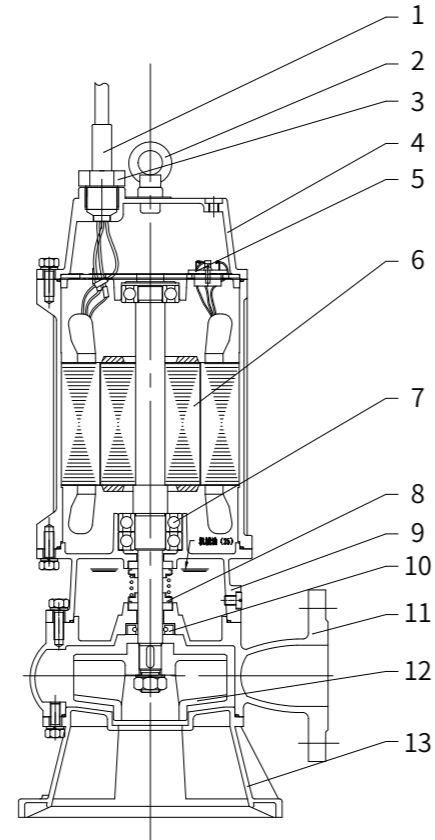

序号 NO.	零件名称 Parts	材料 Material	GB	AISI/ASTM
1	电缆 Cable	/	/	/
2	吊环螺栓 Lifting eye bolt	/	/	/
3	电缆压盖 Cable gland	/	/	/
4	上端盖 Upper end cover	不锈钢 Stainless steel	GB/T 20878-06Cr19Ni10	AISI304
5	热保护器 Thermal protector	/	/	/
6	电机 Motor	/	/	/
7	轴承 Bearing	/	/	/
8	机械密封 Mechanical seal	/	/	/
9	下端盖 Lower end cover	不锈钢 Stainless steel	GB/T 20878-06Cr19Ni10	AISI304
10	骨架油封 Skeleton oil seal	丁腈橡胶 NBR	/	/
11	泵体 Pump body	不锈钢 Stainless steel	GB/T 20878-06Cr19Ni10	AISI304
12	叶轮 Impeller	不锈钢 Stainless steel	GB/T 20878-06Cr19Ni10	AISI304
13	进水口盖 Inlet port cover	不锈钢 Stainless steel	GB/T 20878-06Cr19Ni10	AISI304

## 结构简图 Structure Diagram

WQ(S)型污水污物潜水电泵  
WQ(S)-type submersible sewage pump  
4极电机污水泵截面图  
4-pole motor submersible sewage pump sectional view

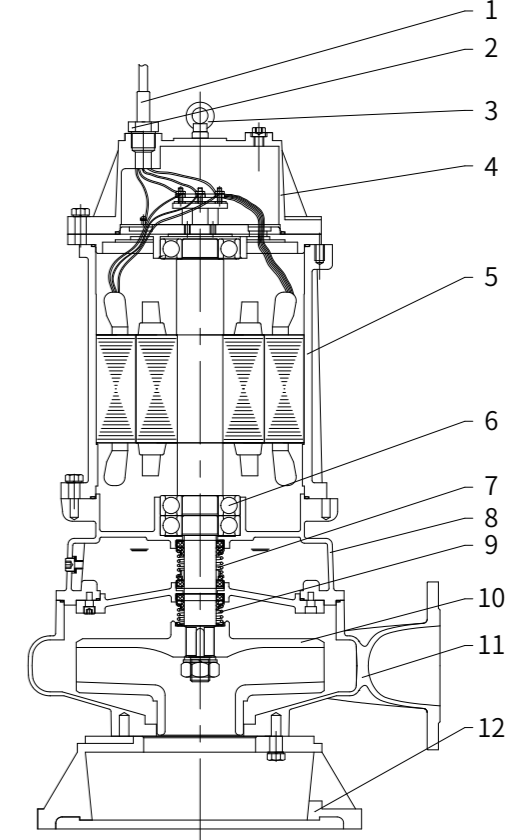

序号 NO.	零件名称 Parts	材料 Material	GB	AISI/ASTM
1	电缆 Cable	/	/	/
2	电缆压盖 Cable gland	/	/	/
3	吊环螺栓 Lifting eye bolt	/	/	/
4	上端盖 Upper end cover	不锈钢 Stainless steel	GB/T 20878-06Cr19Ni10	AISI304
5	电机 Motor	/	/	/
6	轴承 Bearing	/	/	/
7	机械密封 Mechanical seal	/	/	/
8	下端盖 Lower end cover	不锈钢 Stainless steel	GB/T 20878-06Cr19Ni10	AISI304
9	单端面机械密封 Single end face mechanical seal	/	/	/
10	叶轮 Impeller	不锈钢 Stainless steel	GB/T 20878-06Cr19Ni10	AISI304
11	泵体 Pump body	不锈钢 Stainless steel	GB/T 20878-06Cr19Ni10	AISI304
12	进水口底座 Inlet port base	不锈钢 Stainless steel	GB/T 20878-06Cr19Ni10	AISI304

## 切割式污水污物潜水电泵 Cutting Type Submersible Sewage Pump



大流量  
Large flow



高扬程  
High head



安全耐用  
Safe and durable



## 产品概述 Product Overview

1、WQ(D)-QG带切割装置潜水排污泵采用20铬镍钼材质的合金刀盘和叶轮，经过热处理增强了韧性，半开式叶轮设计具有合理的切割构造、合理的水力特性，最大程度避免了水泵出现堵塞现象、不缠绕，流道通过能力强，流量大，扬程高，切割性能好等特点；能将污水中的长纤维、塑料、纸、带、布条、稻草、绳子等杂质切碎后排出。

1. The WQ(D)-QG submersible sewage pump with a cutting device adopts an alloy cutterhead and impeller made of 20CrNiMo material. Through heat treatment, its toughness has been enhanced. The semi-open impeller design features a reasonable cutting structure and hydraulic characteristics, which can, to the greatest extent, avoid the blockage of the pump, prevent winding, and has the advantages of strong passage capacity of the flow channel, large flow, high head, and excellent cutting performance. It can cut and discharge impurities in the sewage, such as long fibers, plastics, paper, strips, cloth strips, straws, ropes, etc.

2、设计的潜水电机，IP68防护，F级绝缘，且潜水冷却效果好，实际温升低，电机绝缘寿命长，7.5kW以下装配有保护器可以保证电机异常情况下能自动切断电源。

2. The designed submersible motor features an IP68 protection level and F-class insulation. It also has excellent submersible cooling performance, resulting in a low actual temperature rise, which extends the insulation service life of the motor. For motors with a power of 7.5kW or less, a protector is installed to ensure that the power supply can be automatically cut off in case of abnormal conditions of the motor.

3、采用双端面机械密封，7.5kW以下外配骨架油封，11kW以上电机轴封采用二至三道串联的机械密封，形成多道可靠的密封防线。一道在泵内介质中，有效地阻止水进入油室，另二道在油室中，防止油进入电机腔内。油室中充有合适的机械油，同时对两个独立机封摩擦面润滑冷却，使机封工作更可靠，除外，它还能带走下轴承的发热和电机一些热量。

3. The pump adopts a double mechanical seal. For pumps with a power of 7.5kW or less, an external skeleton oil seal is used. For motors with a power of 11kW or more, two to three mechanical seals are connected in series for the shaft seal, forming multiple reliable sealing barriers. One seal is located in the medium inside the pump, effectively preventing water from entering the oil chamber. The other two seals are in the oil chamber, preventing oil from entering the motor cavity. The oil chamber is filled with appropriate mechanical oil, which lubricates and cools the friction surfaces of the two independent mechanical seals simultaneously, making the mechanical seals work more reliably. In addition, it can also dissipate the heat generated by the lower bearing and some heat from the motor.

4、部分水泵特殊电缆制作工艺，可完全防止电缆表皮损伤时或者电缆前端浸入水时，水通过线与线之间细小的缝隙浸入电机内部。

4. Some pumps adopt a special cable manufacturing process, which can completely prevent water from seeping into the motor through the tiny gaps between the wires when the cable sheath is damaged or the cable end is immersed in water.

## 使用条件 Usage Conditions

1、电源：50Hz，三相380V；

2、介质温度液体状态下 $\leq 40^{\circ}\text{C}$ ，输送介质的固体物的容积比 $< 2\%$ ，介质密度 $< 1200\text{kg}/\text{m}^3$ ；

3、工作时，最低液不得低于电机的 $2/3$ ；

4、不能适应有腐蚀流体和有腐蚀颗粒的介质；

5、介质中固体物的直径不大于许可通过的最大固体直径；

1. Power supply: 50Hz, three-phase 380V.

2. The temperature of the medium in a liquid state is  $\leq 40^{\circ}\text{C}$ . The volume ratio of solid substances in the conveyed medium is less than 2%. The density of the medium is less than  $1200\text{kg}/\text{m}^3$ .

3. During operation, the minimum liquid level shall not be lower than two-thirds of the motor.

4. It cannot be suitable for corrosive fluids and media containing corrosive particles.

5. The diameter of solid substances in the medium shall not be larger than the maximum allowable diameter of solids that can pass through.

## 应用范围 Application Range

WQ-QG带切割装置潜水排污泵主要用于：

1、建筑工地、工程基础施工、市政设施；

2、各种高楼大厦的地下室、人防坑洞、地铁等地下层污水排放；

3、中小型企业污水处理及循环水输送；

4、食品、造纸、酿造、钢铁及有色金属、制革、纺织、制药、水泥厂等厂矿企业的渣浆液抽送；

5、养鸡场、养猪场等各种养殖业，水池抽水，化粪池等各种场合的人畜粪尿抽送等作用。

The WQ-QG submersible sewage pump with a cutting device is mainly used in the following scenarios:

1. Construction sites, engineering foundation construction, and municipal facilities.

2. Sewage discharge from basements of high-rise buildings, civil air-defense shelters, subways and other underground levels.

3. Sewage treatment and circulating water transportation in small and medium-sized enterprises.

4. Pumping of slag slurry in factories and mines such as food, paper, brewing, iron and non-ferrous metals, leather, textile, pharmaceutical, and cement plants.

5. In various livestock farming industries like chicken farms and pig farms, it can be used for pumping water from ponds and pumping human and animal excrement from septic tanks and other places.

性能曲线 Performance Curves

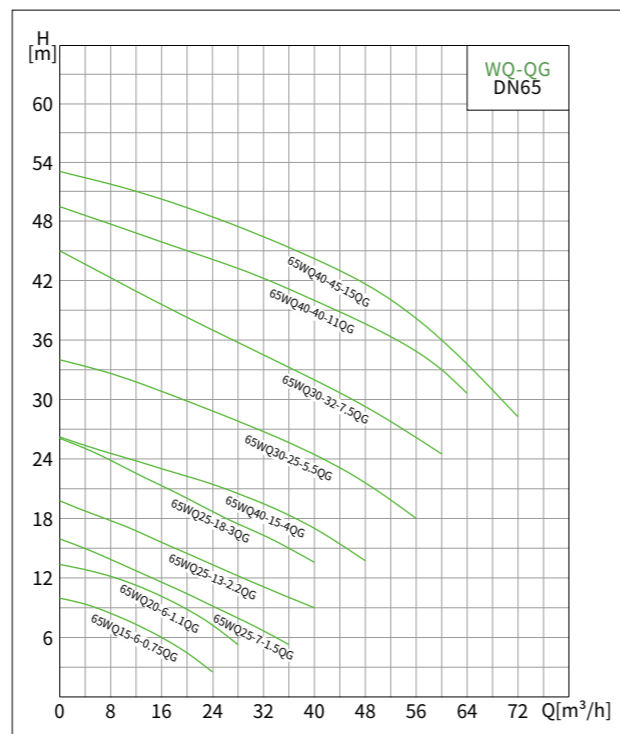
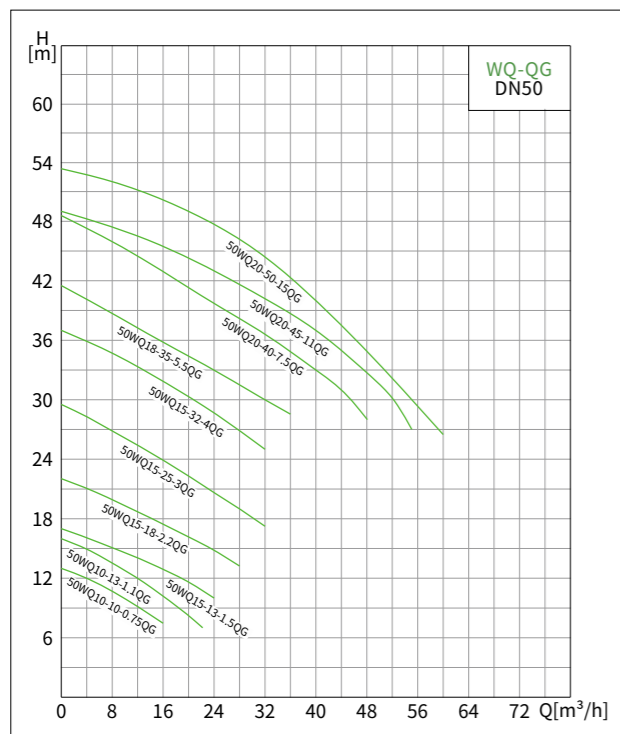

性能曲线 Performance Curves

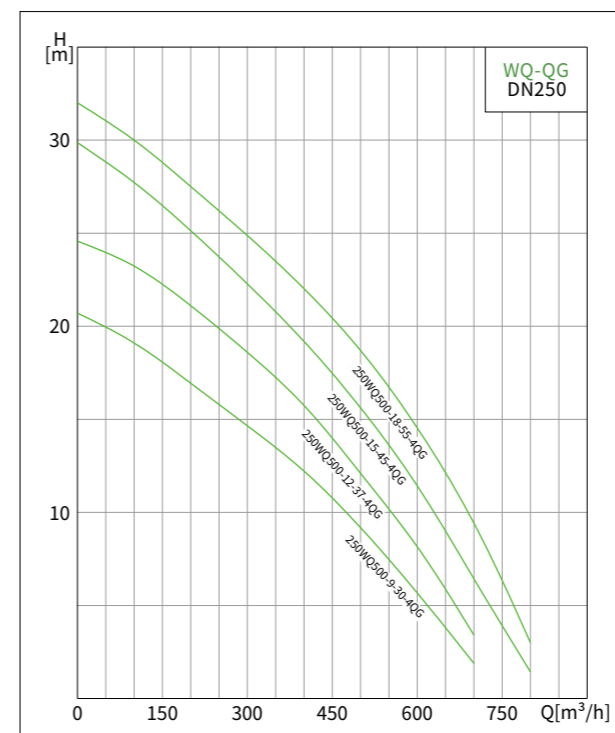
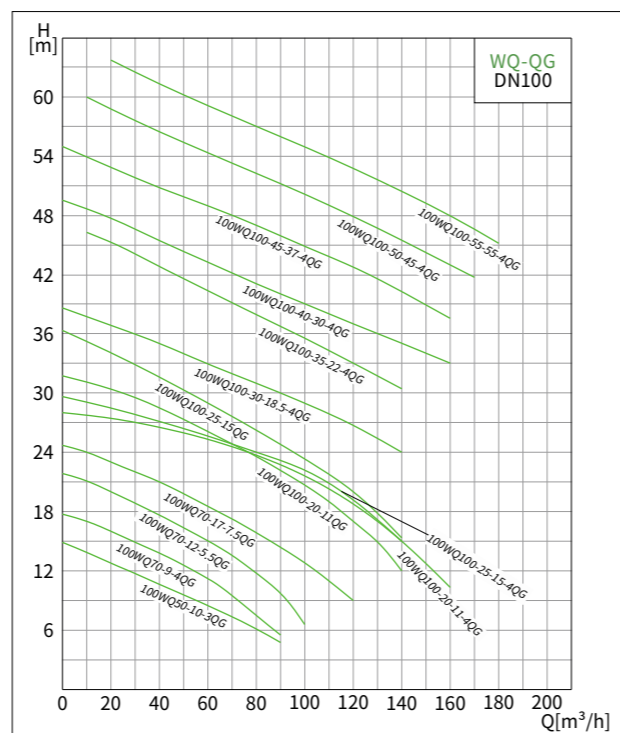
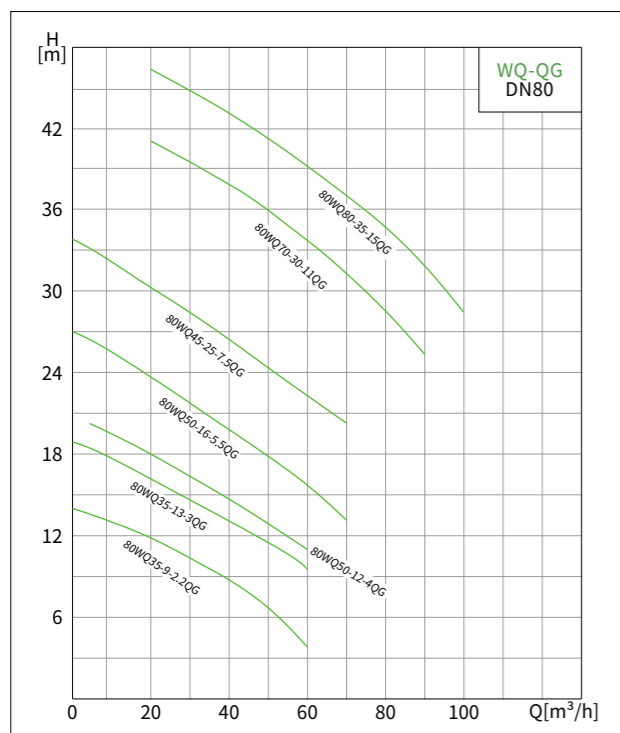
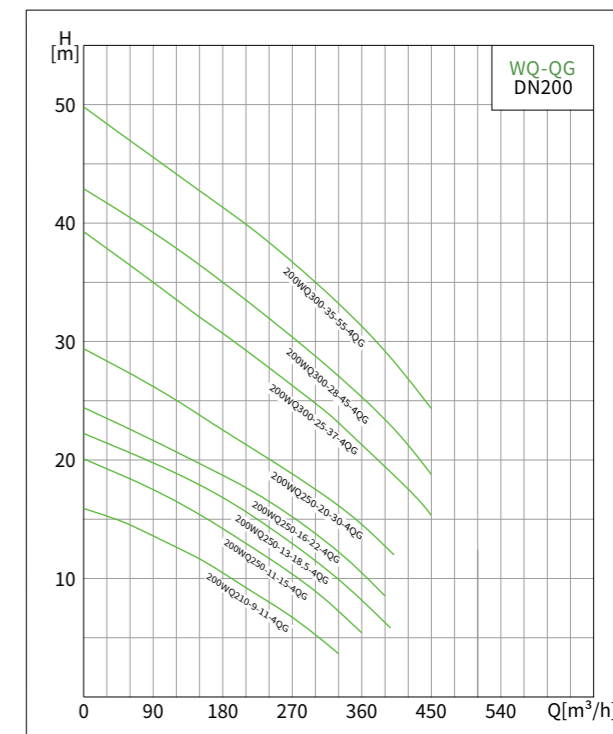
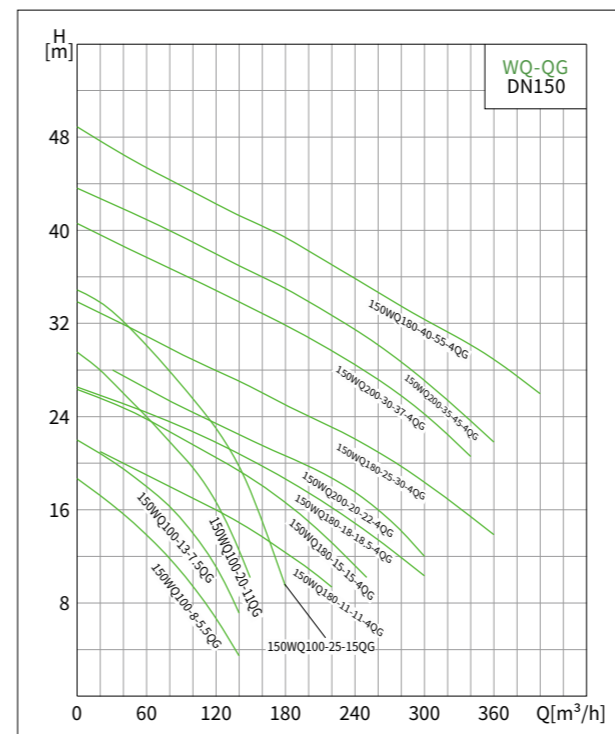

性能参数表 Performance Parameters Form

产品型号 Model	额定流量 Rated flow[m <sup>3</sup> /h]	额定扬程 Rated head[m]	功率 Power[kW]	电压 Voltage[V]	口径 Diameter[mm]	转速 Rotational speed[r/min]
50WQD10-10-0.75QG	10	10	0.75	220	50	2850
50WQ10-10-0.75QG	10	10	0.75	380	50	2850
50WQD10-13-1.1QG	10	13	1.1	220	50	2850
50WQ10-13-1.1QG	10	13	1.1	380	50	2850
50WQD15-13-1.5QG	15	13	1.5	220	50	2850
50WQ15-13-1.5QG	15	13	1.5	380	50	2850
50WQD15-18-2.2QG	15	18	2.2	220	50	2850
50WQ15-18-2.2QG	15	18	2.2	380	50	2850
50WQ15-25-3QG	15	25	3	380	50	2850
50WQ15-32-4QG	15	32	4	380	50	2900
50WQ18-35-5.5QG	18	35	5.5	380	50	2900
50WQ20-40-7.5QG	20	40	7.5	380	50	2900
50WQ20-45-11QG	20	45	11	380	50	2900
50WQ20-50-15QG	20	50	15	380	50	2900
65WQD15-7-0.75QG	15	7	0.75	220	65	2850
65WQ15-7-0.75QG	15	7	0.75	380	65	2850
65WQD15-10-1.1QG	15	10	1.1	220	65	2850
65WQ15-10-1.1QG	15	10	1.1	380	65	2850
65WQD25-10-1.5QG	25	10	1.5	220	65	2850
65WQ25-10-1.5QG	25	10	1.5	380	65	2850
65WQD25-13-2.2QG	25	13	2.2	220	65	2850
65WQ25-13-2.2QG	25	13	2.2	380	65	2850
65WQ25-18-3QG	25	18	3	380	65	2850
65WQ40-15-4QG	40	15	4	380	65	2900
65WQ30-25-5.5QG	30	25	5.5	380	65	2900
65WQ30-32-7.5QG	30	32	7.5	380	65	2900
65WQ40-40-11QG	40	40	11	380	65	2900
65WQ40-45-15QG	40	45	15	380	65	2900
80WQD35-9-2.2QG	35	9	2.2	220	80	2850
80WQ35-9-2.2QG	35	9	2.2	380	80	2850
80WQ35-13-3QG	35	13	3	380	80	2850
80WQ50-12-4QG	50	12	4	380	80	2900
80WQ50-16-5.5QG	50	16	5.5	380	80	2900
80WQ45-22-7.5QG	45	22	7.5	380	80	2900
80WQ60-30-11QG	60	30	11	380	80	2900
80WQ60-40-15QG	60	40	15	380	80	2900
100WQ50-10-3QG	50	10	3	380	100	2850

性能参数表 Performance Parameters Form

产品型号 Model	额定流量 Rated flow[m <sup>3</sup> /h]	额定扬程 Rated head[m]	功率 Power[kW]	电压 Voltage[V]	口径 Diameter[mm]	转速 Rotational speed[r/min]
100WQ70-9-4QG	70	9	4	380	100	2900
100WQ70-12-5.5QG	70	12	5.5	380	100	2900
100WQ70-17-7.5QG	70	17	7.5	380	100	2900
100WQ80-25-11QG	80	25	11	380	100	2900
100WQ80-35-15QG	80	35	15	380	100	2900
150WQ100-8-5.5QG	100	8	5.5	380	150	2900
150WQ140-8-7.5QG	140	8	7.5	380	150	2900
150WQ100-20-11QG	100	20	11	380	150	2900
150WQ100-25-15QG	100	25	15	380	150	2900
100WQ100-20-11QG	100	20	11	380	100	1450
100WQ100-25-15QG	100	25	15	380	100	1450
100WQ100-30-18.5QG	100	30	18.5	380	100	1450
100WQ100-35-22QG	100	35	22	380	100	1450
100WQ100-40-30QG	100	40	30	380	100	1450
100WQ100-45-37QG	100	45	37	380	100	1450
100WQ100-50-45QG	100	50	45	380	100	1450
100WQ100-55-55QG	100	55	55	380	100	1450
150WQ180-11-11QG	180	11	11	380	150	1450
150WQ180-15-15QG	180	15	15	380	150	1450
150WQ180-18-18.5QG	180	18	18.5	380	150	1450
150WQ200-20-22QG	200	20	22	380	150	1450
150WQ180-25-30QG	180	25	30	380	150	1450
150WQ200-30-37QG	200	30	37	380	150	1450
150WQ200-35-45QG	200	35	45	380	150	1450
150WQ180-40-55QG	180	40	55	380	150	1450
200WQ210-9-11QG	210	9	11	380	200	1450
200WQ250-11-15QG	250	11	15	380	200	1450
200WQ250-13-18.5QG	250	13	18.5	380	200	1450
200WQ250-16-22QG	250	16	22	380	200	1450
200WQ250-22-30QG	250	22	30	380	200	1450
200WQ300-25-37QG	300	25	37	380	200	1450
200WQ300-30-45QG	300	30	45	380	200	1450
200WQ300-35-55QG	300	35	55	380	200	1450
250WQ500-9-30QG	500	9	30	380	250	1450
250WQ500-12-37QG	500	12	37	380	250	1450
250WQ500-15-45QG	500	15	45	380	250	1450
250WQ500-18-55QG	500	18	55	380	250	1450

污水污物潜水电泵(可定制高温款) Submersible Sewage Pump(High-temperature models can be customized.)



大流量  
Large flow



高扬程  
High head



安全耐用  
Safe and durable



可加装搅匀装置  
The stirring device  
can be installed.



#### 应用范围 Application Range

- 1、适用于建筑工程施工、工矿企业、市政工程等污水处理系统；
- 2、城市环保系统中排污、污水处理；
- 3、勘探、矿山配套附机；
- 4、农业灌溉、养鱼、喷水等。

1. It is suitable for the sewage treatment systems of construction engineering, industrial and mining enterprises, municipal engineering, etc.
2. Sewage discharge and treatment in urban environmental protection systems.
3. Auxiliary machines for prospecting and mining.
4. Agricultural irrigation, fish farming, water spraying, etc.

#### 产品概述 Product Overview

1、WQ(D)潜水排污泵叶轮采用封闭式形状的双流道设计，因对称流道，平衡性好，运行平稳，振动小增加了产品的使用寿命。流道通过能力强，实测效率高于国家标准，节能降耗。

1. The impeller of the WQ(D) submersible sewage pump adopts a double-flow passage design in a closed shape. Due to the symmetrical flow passages, it has good balance, runs stably, generates less vibration, and thus prolongs the service life of the product. The flow passages have strong passing ability, and the measured efficiency is higher than the national standard, achieving energy conservation and consumption reduction.

2、设计的潜水电机，IP68防护，F级绝缘，且潜水冷却效果好，实际温升低，电机绝缘寿命长，7.5kW以下装配有保护器可以保证电机异常情况下能自动切断电源。

2. The designed submersible motor features an IP68 protection level and F-class insulation. It also has excellent submersible cooling performance, resulting in a low actual temperature rise, which extends the insulation service life of the motor. For motors with a power of 7.5kW or less, a protector is installed to ensure that the power supply can be automatically cut off in case of abnormal conditions of the motor.

3、采用双端面机械密封，7.5kW以下外配骨架油封，11kW以上电机轴封采用二至三道串联的机械密封，形成多道可靠的密封防线。一道在泵内介质中，有效地阻止水进入油室，另二道在油室中，防止油进入电机腔内。油室中充有合适的机械油，同时对两个独立机封摩擦面润滑冷却，使机封工作更可靠，除外，它还能带走下轴承的发热和电机一些热量。

3. The pump adopts a double mechanical seal. For pumps with a power of 7.5kW or less, an external skeleton oil seal is used. For motors with a power of 11kW or more, two to three mechanical seals are connected in series for the shaft seal, forming multiple reliable sealing barriers. One seal is located in the medium inside the pump, effectively preventing water from entering the oil chamber. The other two seals are in the oil chamber, preventing oil from entering the motor cavity. The oil chamber is filled with appropriate mechanical oil, which lubricates and cools the friction surfaces of the two independent mechanical seals simultaneously, making the mechanical seals work more reliably. In addition, it can also dissipate the heat generated by the lower bearing and some heat from the motor.

4、部分水泵特殊电缆制作工艺，可完全防止电缆表皮损伤时或者电缆前端浸入水时，水通过线与线之间细小的缝隙浸入电机内部。

4. Some pumps adopt a special cable manufacturing process, which can completely prevent water from seeping into the motor through the tiny gaps between the wires when the cable sheath is damaged or the cable end is immersed in water.

#### 使用条件 Usage Conditions

- 1、电源：50Hz，三相380V；
- 2、介质温度液体状态下 $\leq 40^{\circ}\text{C}$ ，输送介质的固体物的容积比 $< 2\%$ ，介质密度 $< 1200\text{kg}/\text{m}^3$ ；
- 3、工作时，最低液不得低于电机的 $2/3$ ；
- 4、不能适应有腐蚀流体和有腐蚀颗粒的介质；
- 5、介质中固体物的直径不大于许可通过的最大固体直径；

1. Power supply: 50Hz, three-phase 380V.
2. The temperature of the medium in a liquid state is  $\leq 40^{\circ}\text{C}$ . The volume ratio of solid substances in the conveyed medium is less than 2%. The density of the medium is less than  $1200\text{kg}/\text{m}^3$ .
3. During operation, the minimum liquid level shall not be lower than two-thirds of the motor.
4. It cannot be suitable for corrosive fluids and media containing corrosive particles.
5. The diameter of solid substances in the medium shall not be larger than the maximum allowable diameter of solids that can pass through.

性能曲线 Performance Curves

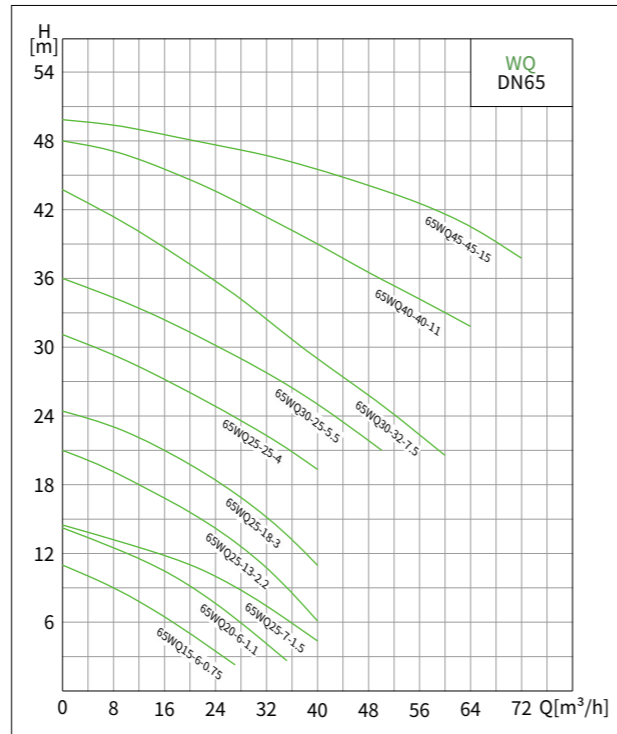
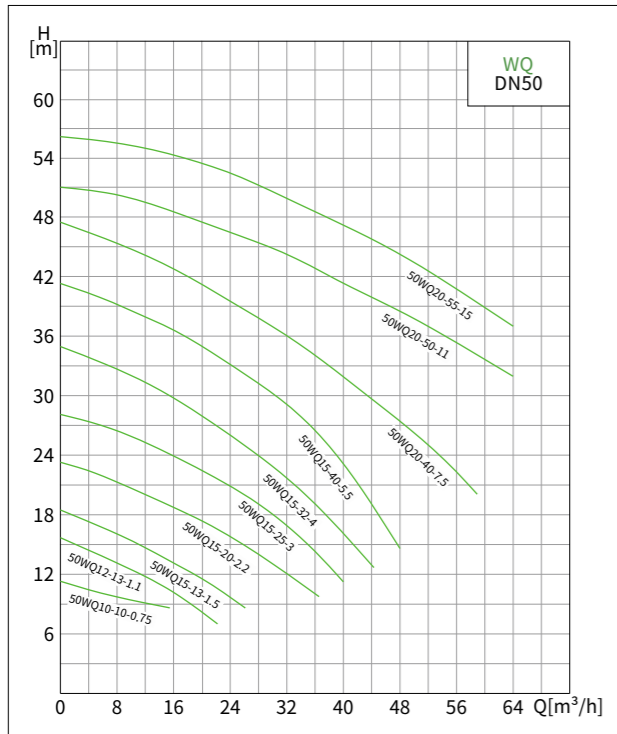

性能曲线 Performance Curves

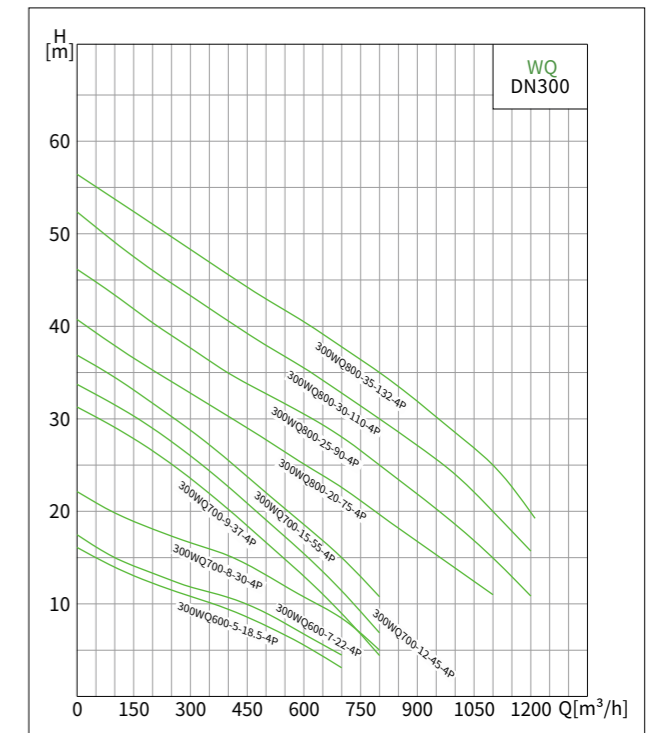
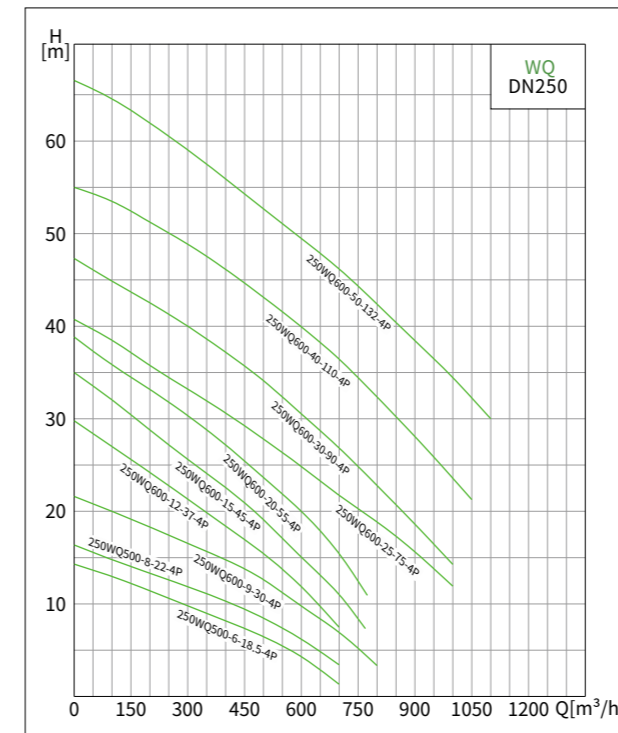
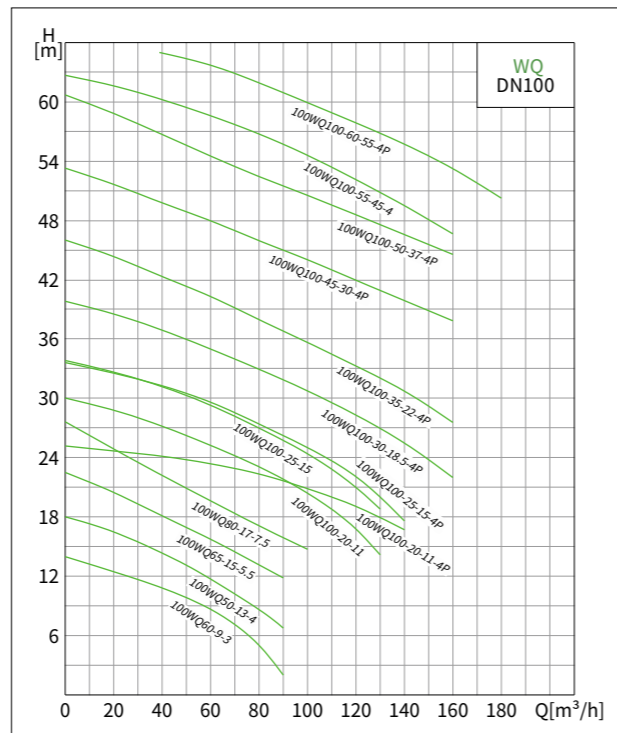
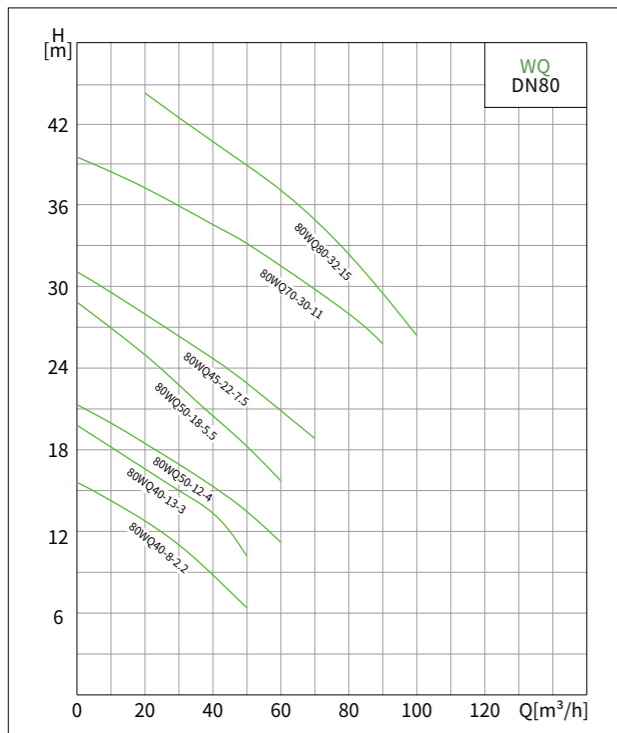
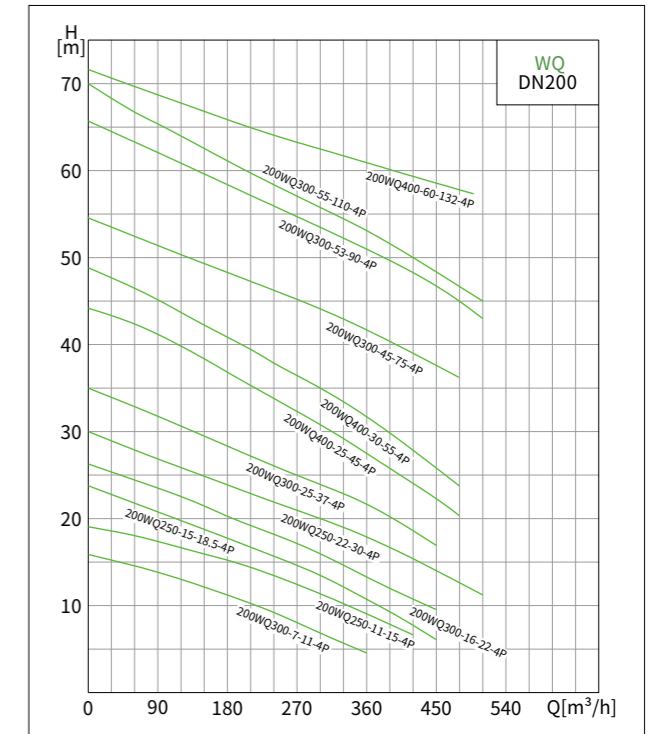
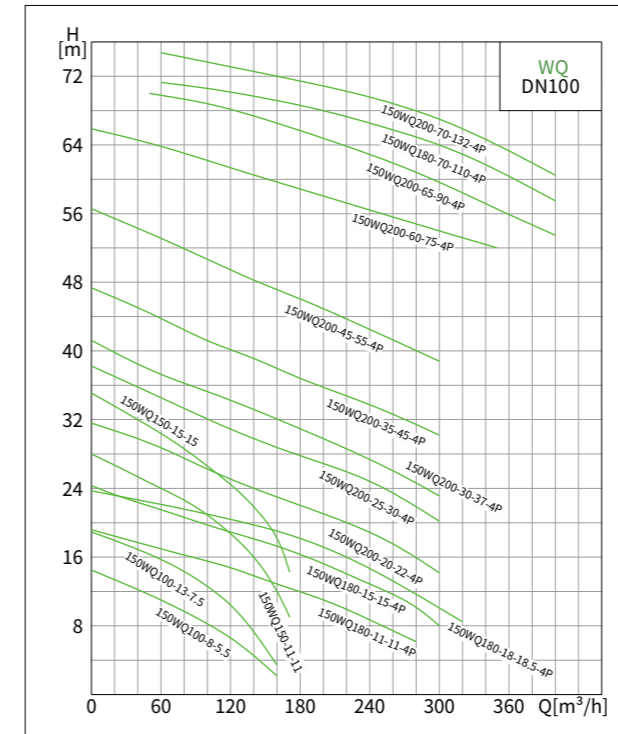

性能参数表 Performance Parameters Form

产品型号 Model	额定流量 Rated flow[m <sup>3</sup> /h]	额定扬程 Rated head[m]	功率 Power[kW]	电压 Voltage[V]	口径 Diameter[mm]	转速 Rotational speed[r/min]
50WQD10-10-0.75	10	10	0.75	220	50	2850
50WQ10-10-0.75	10	10	0.75	380	50	2850
50WQD10-13-1.1	10	13	1.1	220	50	2850
50WQ10-13-1.1	10	13	1.1	380	50	2850
50WQD15-15-1.5	25	25	1.5	220	50	2850
50WQ15-15-1.5	15	15	1.5	380	50	2850
50WQD15-20-2.2	15	20	2.2	220	50	2850
50WQ15-20-2.2	15	20	2.2	220	50	2850
50WQ15-25-3	15	25	3	380	50	2850
50WQ15-32-4	15	32	4	380	50	2900
50WQ15-40-5.5	15	40	5.5	380	50	2900
50WQ20-40-7.5(I)	20	40	7.5	380	50	2900
50WQ20-40-7.5	20	40	7.5	380	50	2900
50WQ20-50-11	20	50	11	380	50	2900
50WQ20-55-15	20	55	15	380	50	2900
65WQD15-6-0.75	15	6	0.75	220	65	2850
65WQ15-6-0.75	15	6	0.75	380	65	2850
65WQD20-6-1.1	20	6	1.1	220	65	2850
65WQ20-6-1.1	20	6	1.1	380	65	2850
65WQD25-7-1.5	25	7	1.5	220	65	2850
65WQ25-7-1.5	25	7	1.5	380	65	2850
65WQD25-15-2.2	25	15	2.2	220	65	2850
65WQ25-15-2.2	25	15	2.2	220	65	2850
65WQ25-20-3	25	20	3	380	65	2850
65WQ25-25-4	25	25	4	380	65	2900
65WQ30-25-5.5	30	25	5.5	380	65	2900
65WQ30-32-7.5(I)	30	32	7.5	380	65	2900
65WQ30-32-7.5	30	32	7.5	380	65	2900
65WQ40-40-11	40	40	11	380	65	2900
65WQ45-45-15	45	45	15	380	65	2900
80WQD40-9-2.2	40	9	2.2	220	80	2850
80WQ40-9-2.2	40	9	2.2	220	80	2850
80WQ40-15-3	40	15	3	380	80	2850
80WQ40-18-4	40	18	4	380	80	2900
80WQ50-18-5.5	50	18	5.5	380	80	2900
80WQ45-22-7.5(I)	45	22	7.5	380	80	2900
80WQ45-22-7.5	45	22	7.5	380	80	2900

性能参数表 Performance Parameters Form

产品型号 Model	额定流量 Rated flow[m <sup>3</sup> /h]	额定扬程 Rated head[m]	功率 Power[kW]	电压 Voltage[V]	口径 Diameter[mm]	转速 Rotational speed[r/min]
80WQ60-30-11	60	30	11	380	80	2900
80WQ80-32-15	80	32	15	380	80	2900
100WQ50-10-3	50	10	3	380	100	2850
100WQ50-13-4	50	13	4	380	100	2900
100WQ70-15-5.5	70	15	5.5	380	100	2900
100WQ80-18-7.5(I)	80	18	7.5	380	100	2900
100WQ80-18-7.5	80	18	7.5	380	100	2900
100WQ100-20-11	100	20	11	380	100	2900
100WQ100-25-15	100	25	15	380	100	2900
150WQ100-8-5.5	100	8	5.5	380	150	2900
150WQ100-13-7.5(I)	100	13	7.5	380	150	2900
150WQ100-13-7.5	100	13	7.5	380	150	2900
150WQ150-11-11	150	11	11	380	150	2900
150WQ150-15-15	150	15	15	380	150	2900
200WQ200-8-11	200	8	11	380	200	2900
200WQ220-10-15	220	10	15	380	200	2900
100WQ100-20-11	100	20	11	380	100	1450
100WQ100-25-15	100	25	15	380	100	1450
100WQ100-30-18.5	100	30	18.5	380	100	1450
100WQ100-35-22	100	35	22	380	100	1450
100WQ100-45-30	100	45	30	380	100	1450
100WQ100-50-37	100	50	37	380	100	1450
100WQ100-55-45	100	55	45	380	100	1450
100WQ100-65-55	100	65	55	380	100	1450
150WQ180-11-11	180	11	11	380	150	1450
150WQ180-15-15	180	15	15	380	150	1450
150WQ180-18-18.5	180	18	18.5	380	150	1450
150WQ200-20-22	200	20	22	380	150	1450
150WQ180-30-30	180	30	30	380	150	1450
150WQ200-30-37	200	30	37	380	150	1450
150WQ200-35-45	200	35	45	380	150	1450
150WQ180-50-55	180	50	55	380	150	1450
150WQ200-60-75	200	60	75	380	150	1450
150WQ200-65-90	200	65	90	380	150	1450
150WQ200-75-110	200	75	110	380	150	1450
150WQ200-80-132	200	80	132	380	150	1450
200WQ300-7-11	300	7	11	380	200	1450

性能参数表 Performance Parameters Form

产品型号 Model	额定流量 Rated flow[m <sup>3</sup> /h]	额定扬程 Rated head[m]	功率 Power[kW]	电压 Voltage[V]	口径 Diameter[mm]	转速 Rotational speed[r/min]
200WQ250-11-15	250	11	15	380	200	1450
200WQ250-15-18.5	250	15	18.5	380	200	1450
200WQ300-16-22	300	16	22	380	200	1450
200WQ250-22-30	250	22	30	380	200	1450
200WQ350-25-37	350	25	37	380	200	1450
200WQ400-25-45	400	25	45	380	200	1450
200WQ300-40-55	300	40	55	380	200	1450
200WQ400-30-55	400	30	55	380	200	1450
200WQ300-45-75	300	45	75	380	200	1450
200WQ300-55-90	300	55	90	380	200	1450
200WQ400-50-90	400	50	90	380	200	1450
200WQ400-55-110	400	55	110	380	200	1450
200WQ400-60-132	400	60	132	380	200	1450
250WQ500-6-18.5	500	6	18.5	380	250	1450
250WQ500-8-22	500	8	22	380	250	1450
250WQ600-9-30	600	9	30	380	250	1450
250WQ600-12-37	600	12	37	180	250	1450
250WQ600-15-45	600	15	45	380	250	1450
250WQ600-20-55	600	20	55	380	250	1450
250WQ600-25-75	600	25	75	380	250	1450
250WQ600-30-90	600	30	90	380	250	1450
250WQ600-40-110	600	40	110	380	250	1450
250WQ600-50-132	600	50	132	380	250	1450
300WQ800-7-30	800	7	30	380	300	1450
300WQ800-9-37	800	9	37	380	300	1450
300WQ800-12-45	800	12	45	380	300	1450
300WQ800-15-55	800	15	55	380	300	1450
300WQ800-20-75	800	20	75	380	300	1450
300WQ800-25-90	800	25	90	380	300	1450
300WQ800-30-110	800	30	110	380	300	1450
300WQ800-35-132	800	35	132	380	300	1450
350WQ1000-6-37	1000	6	37	380	350	1450
350WQ1000-8-45	1000	8	45	380	350	1450
350WQ1000-10-55	1000	10	55	380	350	1450
350WQ900-15-75	900	15	75	380	350	1450
350WQ1000-18-90	1000	18	90	380	350	1450
350WQ1000-22-110	1000	22	110	380	350	1450
350WQ1000-28-132	1000	28	132	380	350	1450

不锈钢切割式污水泵(国标法兰) Stainless Steel Cutting Submersible Sewage Pump(National Standard Flange)



大流量  
Large flow



高扬程  
High head



安全耐用  
Safe and durable



#### 产品概述 Product Overview

1、WQ(D)-QG(S)不锈钢切割式污水泵采用不锈钢精密铸造外壳，具有自身无污染且耐腐蚀的特点，扩大了给排水的应用领域；叶轮采用半开放式形状的双流道设计，进水口采用旋风式镰的固定底座。当叶轮旋转时，叶片的边缘与镰刀状进水口底座盖板相反运动，拥有高效率的切割功能。

1. The WQ(D)-QG(S) stainless steel cutting submersible sewage pump adopts a stainless steel precision-cast casing, which has the characteristics of being free from self-contamination and resistant to corrosion, thus expanding the application fields of water supply and drainage. The impeller adopts a double-flow passage design in a semi-open shape, and the water inlet is equipped with a fixed base in the shape of a cyclone sickle. When the impeller rotates, the edges of the blades move in the opposite direction to the cover plate of the sickle-shaped water inlet base, enabling a highly efficient cutting function.

2、设计的潜水电机，IP68防护，F级绝缘，且潜水冷却效果好，实际温升低，电机绝缘寿命长，7.5kW以下装配有保护器可以保证电机异常情况下能自动切断电源。

2. The designed submersible motor features an IP68 protection level and F-class insulation. It also has excellent submersible cooling performance, resulting in a low actual temperature rise, which extends the insulation service life of the motor. For motors with a power of 7.5kW or less, a protector is installed to ensure that the power supply can be automatically cut off in case of abnormal conditions of the motor.

3、采用氟橡胶双端面波纹管机械密封，油室中充有合适的机械油，同时对两个独立机封摩擦面润滑冷却，使机封工作更可靠，除外，它还能带走下轴承的发热和电机一些热量。

3. It adopts a fluororubber double-face bellows mechanical seal. The oil chamber is filled with appropriate mechanical oil, which lubricates and cools the friction surfaces of the two independent mechanical seals simultaneously, making the mechanical seals work more reliably. In addition, it can also dissipate the heat generated by the lower bearing and some heat from the motor.

4、部分水泵特殊电缆制作工艺，可完全防止电缆表皮损伤时或者电缆前端浸入水时，水通过线与线之间细小的缝隙浸入电机内部。

4. Some pumps adopt a special cable manufacturing process, which can completely prevent water from seeping into the motor through the tiny gaps between the wires when the cable sheath is damaged or the cable end is immersed in water.

使用条件 Usage Conditions

- 1、电源: 50Hz, 三相380V;
- 2、介质温度液体状态下 $\leq 40^{\circ}\text{C}$ , 输送介质的固体物的容积比 $< 2\%$ , 介质密度 $< 1200\text{kg}/\text{m}^3$ ;
- 3、工作时, 最低液不得低于电机的2/3;
- 4、介质中固体物的直径不大于许可通过的最大固体直径;
- 5、输送介质(温度有关)的pH值: 304(4-10)、316(4-13)、316L(3-13)仅供参考。
  1. Power supply: 50Hz, three-phase 380V.
  2. The temperature of the medium in a liquid state is  $\leq 40^{\circ}\text{C}$ . The volume ratio of solid substances in the conveyed medium is less than 2%. The density of the medium is less than  $1200\text{kg}/\text{m}^3$ .
  3. During operation, the minimum liquid level shall not be lower than two-thirds of the motor.
  4. The diameter of solid substances in the medium shall not be larger than the maximum allowable diameter of solids that can pass through.
  5. The pH values of the conveyed medium (temperature-related) are as follows: 4-10 for 304 material, 4-13 for 316 material, and 3-13 for 316L material. These values are for reference only.

应用范围 Application Range

WQ(D)-QG(S)带切割装置潜水排污泵主要用于:

- 1、工程污水, 生活污水;
- 2、用于建筑工地、工程基础施工、市政设施、自来水厂;
- 3、各种高楼大厦的地下室、人防坑洞、地铁等地下层污水排放;
- 4、中小型企业污水处理及循环水输送;
- 5、食品、造纸、酿造、钢铁及有色金属、制革、纺织、制药、水泥厂等厂矿企业的渣浆液抽送;
- 6、养鸡场, 养猪场、各种养殖业, 鱼池作抽水清塘, 化粪池等各种场合的人畜粪尿抽送等作用。

The WQ-QG submersible sewage pump with a cutting device is mainly used in the following scenarios:

1. Engineering sewage and domestic sewage.
2. Applicable to construction sites, engineering foundation construction, municipal facilities, and waterworks.
3. Sewage discharge from basements of high-rise buildings, civil air-defense shelters, subways and other underground levels.
4. Sewage treatment and circulating water transportation in small and medium-sized enterprises.
5. Pumping of slag slurry in factories and mines such as food, paper, brewing, iron and non-ferrous metals, leather, textile, pharmaceutical, and cement plants.
6. In various livestock farming industries like chicken farms and pig farms, it can be used for pumping water from ponds and pumping human and animal excrement from septic tanks and other places.

性能曲线 Performance Curves

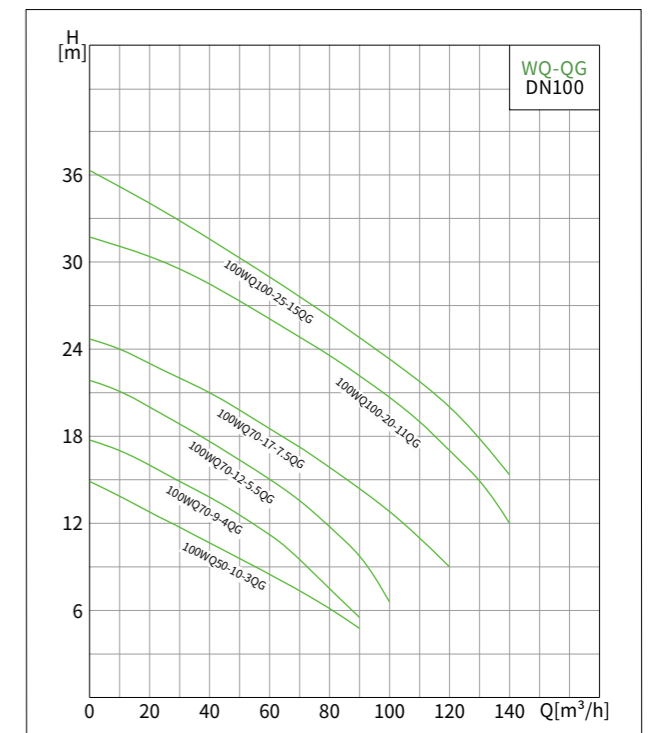
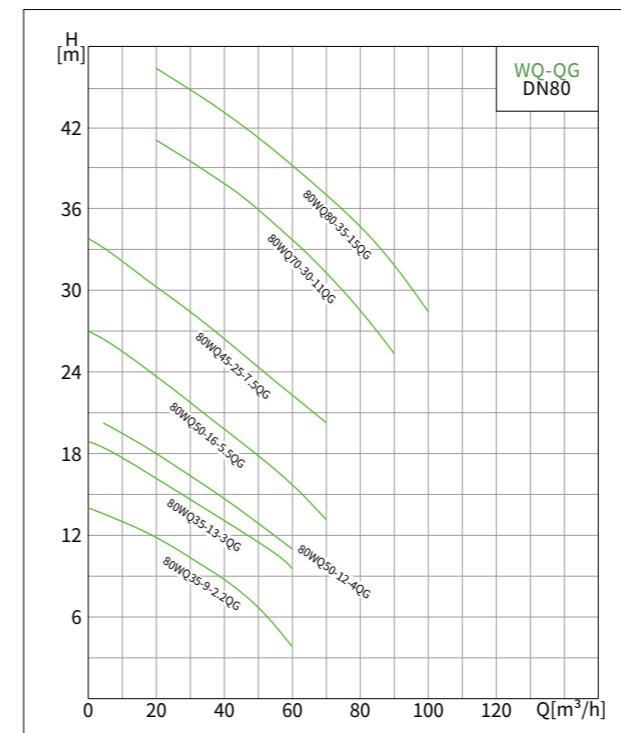
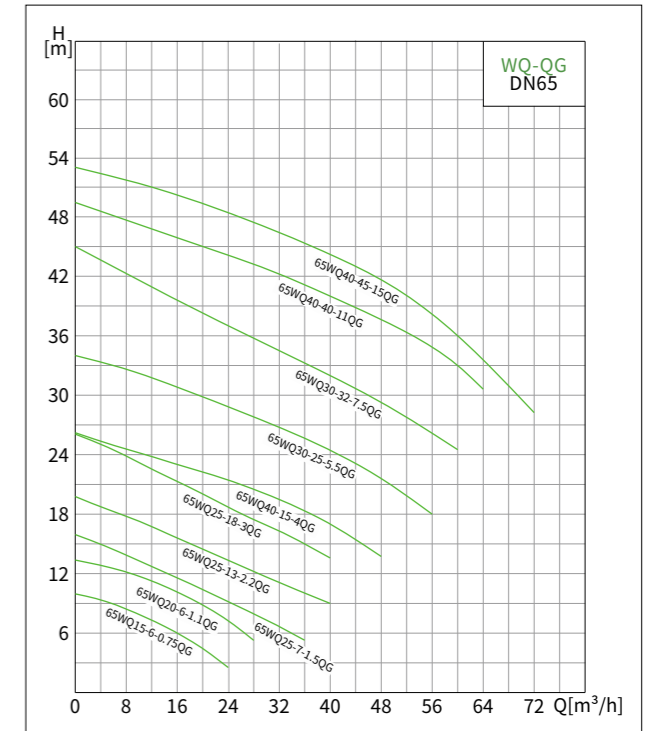
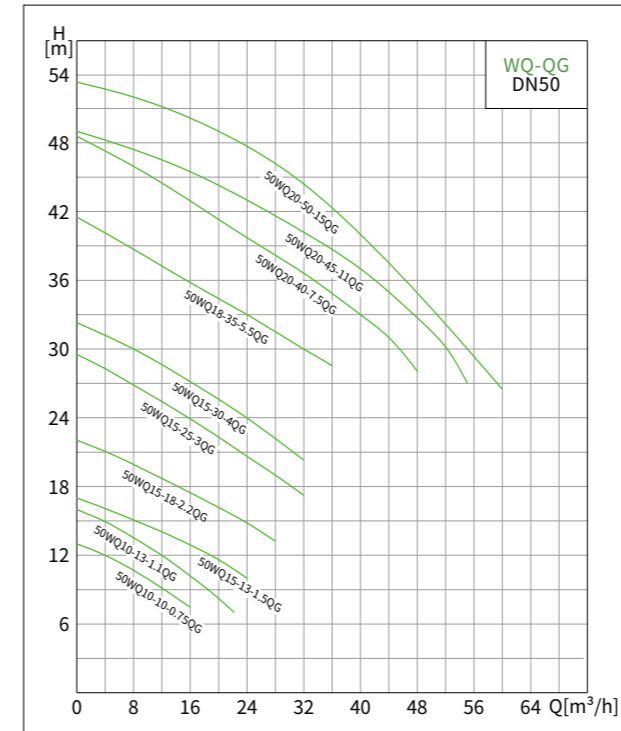

性能曲线 Performance Curves

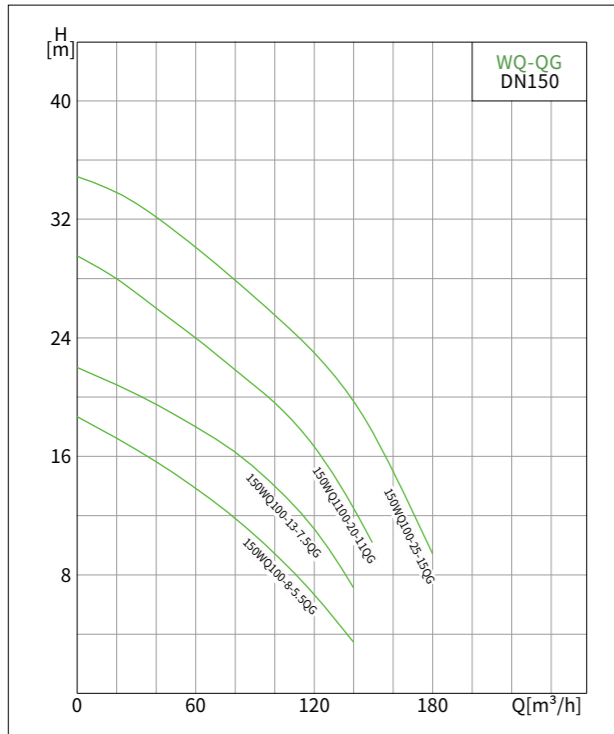

性能参数表 Performance Parameters Form

产品型号 Model	额定流量 Rated flow[m³/h]	额定扬程 Rated head[m]	功率 Power[kW]	电压 Voltage[V]	口径 Diameter[mm]	转速 Rotational speed[r/min]
50WQD10-10-0.75QG	10	10	0.75	220	50	2850
50WQ10-10-0.75QG	10	10	0.75	380	50	2850
50WQD10-13-1.1QG	10	13	1.1	220	50	2850
50WQ10-13-1.1QG	10	13	1.1	380	50	2850
50WQD15-13-1.5QG(I)	15	13	1.5	220	50	2850
50WQ15-13-1.5QG(I)	15	13	1.5	380	50	2850
50WQD15-13-1.5QG	15	13	1.5	220	50	2850
50WQ15-13-1.5QG	15	13	1.5	380	50	2850
50WQ15-18-2.2QG(I)	15	18	2.2	380	50	2850
50WQD15-18-2.2QG	15	18	2.2	380	50	2850
50WQ15-18-2.2QG	15	18	2.2	380	50	2850
50WQ15-25-3QG	15	25	3	380	50	2850
50WQ15-32-4QG(I)	15	32	4	380	50	2900
50WQ15-32-4QG	15	32	4	380	50	2900
50WQ18-35-5.5QG	18	35	5.5	380	50	2900
50WQ20-40-7.5QG	20	40	7.5	380	50	2900
50WQ20-45-11QG	20	45	11	380	50	2900
50WQ20-50-15QG	20	50	15	380	50	2900

性能曲线 Performance Curves

产品型号 Model	额定流量 Rated flow[m³/h]	额定扬程 Rated head[m]	功率 Power[kW]	电压 Voltage[V]	口径 Diameter[mm]	转速 Rotational speed[r/min]
65WQD15-6-0.75QG	15	6	0.75	220	65	2850
65WQ15-6-0.75QG	15	6	0.75	380	65	2850
65WQD20-6-1.1QG	20	3	1.1	220	65	2850
65WQ20-6-1.1QG	20	6	1.1	380	65	2850
65WQD25-7-1.5QG(I)	25	7	1.5	220	35	2850
65WQ25-7-1.5QG(I)	25	7	1.5	380	65	2850
65WQD25-7-1.5QG	25	7	1.5	220	65	2850
65WQ25-7-1.5QG	25	7	1.5	380	65	2850
65WQ25-13-2.2QG(I)	25	13	2.2	380	65	2850
65WQD25-13-2.2QG	25	13	2.2	380	65	2850
65WQ25-13-2.2QG	25	13	2.2	380	65	2850
65WQ25-18-3QG	25	18	3	380	65	2850
65WQ40-15-4QG(I)	40	15	4	380	65	2900
65WQ40-15-4QG	40	15	4	380	65	2900
65WQ30-25-5.5QG	30	25	5.5	380	65	2900
65WQ30-32-7.5QG	30	32	7.5	380	65	2900
65WQ40-40-11QG	40	40	11	380	65	2900
65WQ40-45-15QG	40	45	15	380	65	2900
80WQ35-9-2.2QG(I)	35	9	2.2	380	80	2850
80WQD35-9-2.2QG	35	9	2.2	380	80	2850
80WQ35-9-2.2QG	35	9	2.2	380	80	2850
80WQ35-13-3QG	35	13	3	380	80	2850
80WQ50-12-4QG(I)	50	12	4	380	80	2900
80WQ50-12-4QG	50	12	4	380	80	2900
80WQ50-16-5.5QG	50	16	5.5	380	80	2900
80WQ45-22-7.5QG	45	22	7.5	380	80	2900
80WQ70-30-11QG	70	30	11	380	80	2900
80WQ70-35-15QG	70	35	15	380	80	2900
100WQ70-9-4QG(I)	70	9	4	380	100	2900
100WQ70-9-4QG	70	9	4	380	100	2900
100WQ70-12-5.5QG	70	12	5.5	380	100	2900
100WQ70-17-7.5QG	70	17	7.5	380	100	2900
100WQ100-20-11QG	100	20	11	380	100	2900
100WQ100-25-15QG	100	25	15	380	100	2900
150WQ140-8-7.5QG	140	8	7.5	380	150	2900
150WQ120-15-11QG	120	15	11	380	150	2900
150WQ120-20-15QG	120	20	15	380	150	2900

## 不锈钢污水污物潜水电泵(国标法兰) Stainless Steel Submersible Sewage Pump(National Standard Flange)

大流量  
Large flow高扬程  
High head安全耐用  
Safe and durable可加装搅匀装置  
Agitation device  
can be added.

## 应用范围 Application Range

- 1、适用于建筑工程施工、工矿企业、市政工程等污水处理系统;
  - 2、城市环保系统中排污、污水处理;
  - 3、勘探、矿山配套附机;
  - 4、食品、医疗、海水排吸、船舱积水等污水排放;
  - 5、农业灌溉、农村沼气池、养鱼、喷泉、喷水等。
1. It is suitable for the sewage treatment systems of construction engineering, industrial and mining enterprises, municipal engineering, etc.
  2. Sewage discharge and treatment in urban environmental protection systems.
  3. Auxiliary machines for prospecting and mining.
  4. Sewage discharge for food industry, medical field, seawater suction and discharge, water accumulation in ship cabins, etc.
  5. Agricultural irrigation, rural biogas digesters, fish farming, fountains, water spraying, etc.

## 产品概述 Product Overview

- 1、WQ(D)-S不锈钢污水污物潜水电泵采用不锈钢精密铸造外壳，具有自身无污染且耐腐蚀的特点，扩大了给排水的应用领域；叶轮采用封闭式形状的双流道设计，因对称流道，平衡性好，运行平稳，振动小增加了产品的使用寿命。流道通过能力强，实测效率高于国家标准，节能降耗。
1. The WQ(D)-S stainless steel cutting submersible sewage pump adopts a stainless steel precision-cast casing, which has the characteristics of being free from self-contamination and resistant to corrosion, thus expanding the application fields of water supply and drainage. The impeller adopts a double-flow passage design in a closed shape. Due to the symmetrical flow passages, it has good balance, runs stably, generates less vibration, and thus prolongs the service life of the product. The flow passages have strong passing ability, and the measured efficiency is higher than the national standard, achieving energy conservation and consumption reduction.
- 2、设计的潜水电机，IP68防护，F级绝缘，且潜水冷却效果好，实际温升低，电机绝缘寿命长，7.5kW以下装配有保护器可以保证电机异常情况下能自动切断电源。
2. The designed submersible motor features an IP68 protection level and F-class insulation. It also has excellent submersible cooling performance, resulting in a low actual temperature rise, which extends the insulation service life of the motor. For motors with a power of 7.5kW or less, a protector is installed to ensure that the power supply can be automatically cut off in case of abnormal conditions of the motor.
- 3、采用氟橡胶双端面机械密封，7.5kW以下外配骨架油封，11kW以上电机轴封采用二至三道串联的机械密封，形成多道可靠的密封防线。一道在泵内介质中，有效地阻止水进入油室，另二道在油室中，防止油进入电机腔内。油室中充有合适的机械油，同时对两个独立机封摩擦面润滑冷却，使机封工作更可靠，除外，它还能带走下轴承的发热和电机一些热量。
3. The pump adopts a fluororubber double-face mechanical seal. For pumps with a power of 7.5kW or less, an external skeleton oil seal is used. For motors with a power of 11kW or more, two to three mechanical seals are connected in series for the shaft seal, forming multiple reliable sealing barriers. One seal is located in the medium inside the pump, effectively preventing water from entering the oil chamber. The other two seals are in the oil chamber, preventing oil from entering the motor cavity. The oil chamber is filled with appropriate mechanical oil, which lubricates and cools the friction surfaces of the two independent mechanical seals simultaneously, making the mechanical seals work more reliably. In addition, it can also dissipate the heat generated by the lower bearing and some heat from the motor.
- 4、部分水泵特殊电缆制作工艺，可完全防止电缆表皮损伤时或者电缆前端浸入水时，水通过线与线之间细小的缝隙浸入电机内部。
4. Some pumps adopt a special cable manufacturing process, which can completely prevent water from seeping into the motor through the tiny gaps between the wires when the cable sheath is damaged or the cable end is immersed in water.
- 5、根据客户的要求，可带搅匀装置，该装置随电机轴旋转产生极强的搅拌力，将污水池内的沉积物搅拌成悬浮物后排出。
5. According to the customer's requirements, a stirring device can be equipped. This device generates a very strong stirring force as it rotates along with the motor shaft, stirring the sediments in the sewage tank into suspended substances before discharging them.

## 使用条件 Usage Conditions

- 1、电源：50Hz，三相380V；
  - 2、介质温度液体状态下 $\leq 40^{\circ}\text{C}$ ，输送介质的固体物的容积比 $< 2\%$ ，介质密度 $< 1200\text{kg}/\text{m}^3$ ；
  - 3、工作时，最低液不得低于电机的 $2/3$ ；
  - 4、介质中固体物的直径不大于许可通过的最大固体直径；
  - 5、输送介质(温度有关)的pH值：304(4-10)、316(4-13)、316L(3-13)仅供参考。
1. Power supply: 50Hz, three-phase 380V.
  2. The temperature of the medium in a liquid state is  $\leq 40^{\circ}\text{C}$ . The volume ratio of solid substances in the conveyed medium is less than 2%. The density of the medium is less than  $1200\text{kg}/\text{m}^3$ .
  3. During operation, the minimum liquid level shall not be lower than two-thirds of the motor.
  4. The diameter of solid substances in the medium shall not be larger than the maximum allowable diameter of solids that can pass through.
  5. The pH values of the conveyed medium (temperature-related) are as follows: 4-10 for 304 material, 4-13 for 316 material, and 3-13 for 316L material. These values are for reference only.

性能曲线 Performance Curves

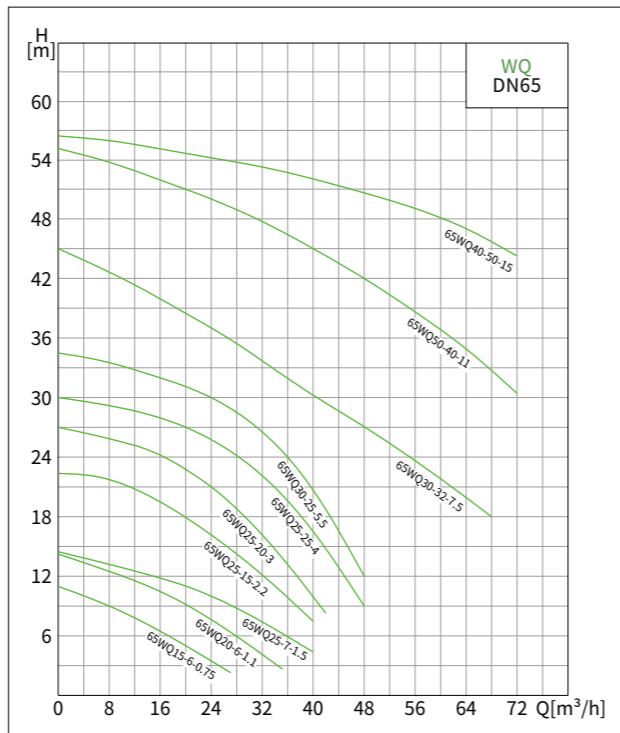
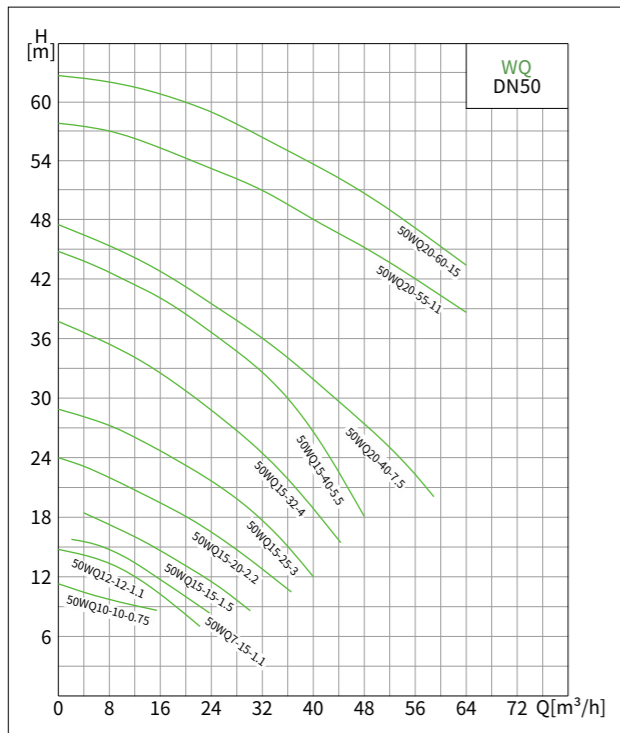

性能曲线 Performance Curves

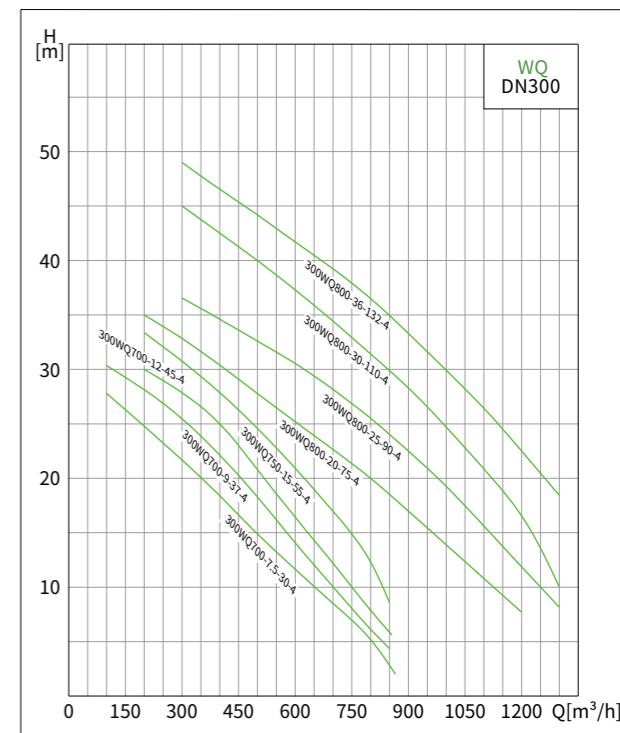
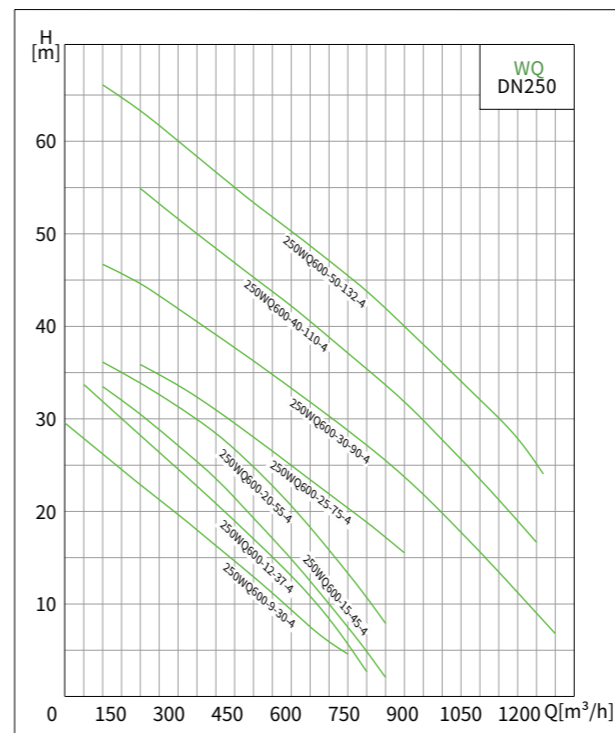
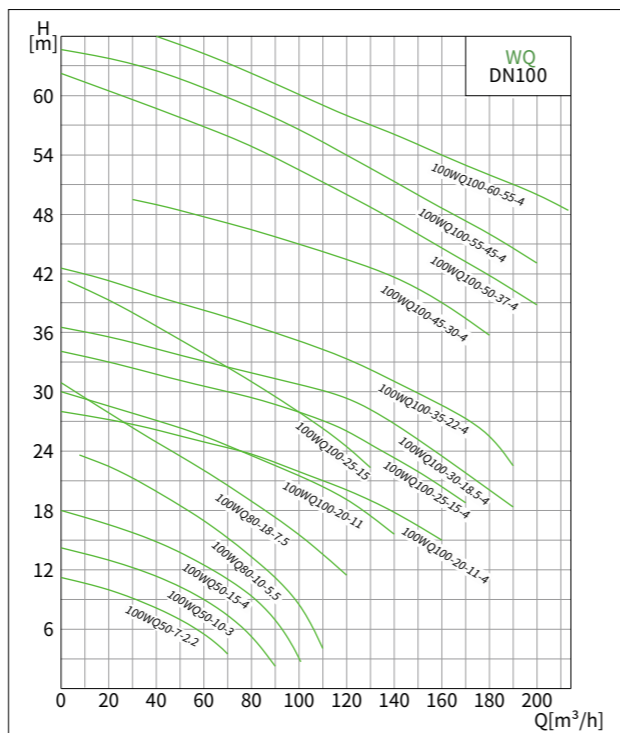
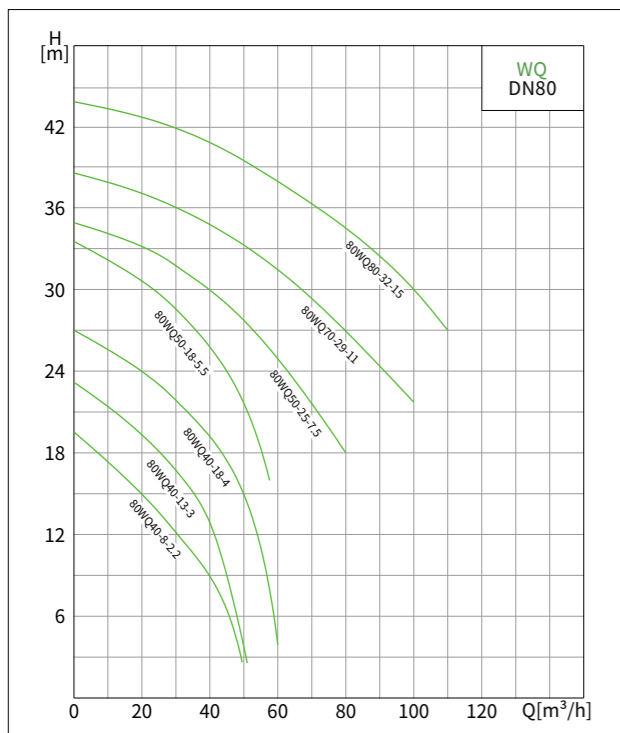
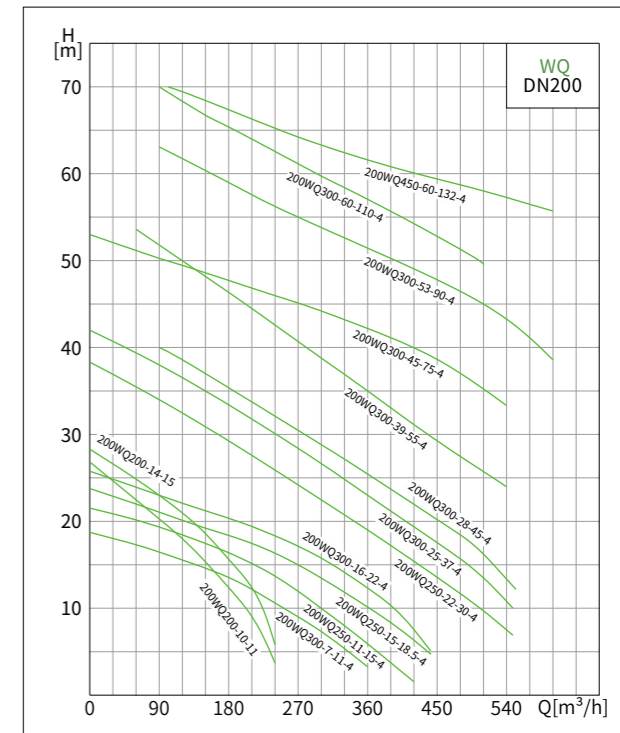
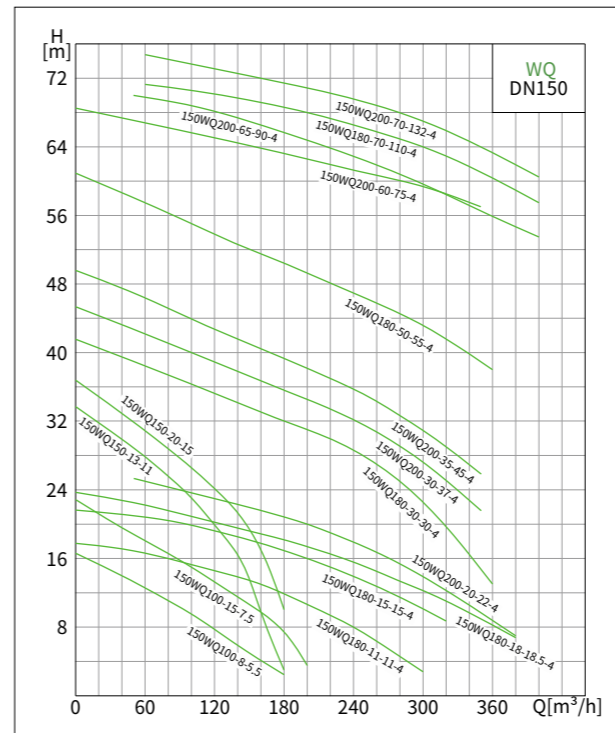

性能曲线 Performance Curves

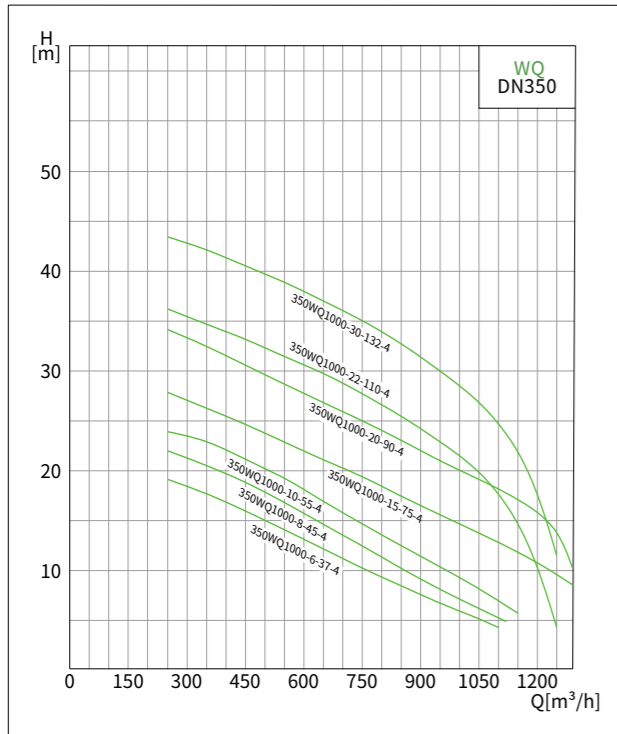

性能曲线 Performance Curves

产品型号 Model	额定流量 Rated flow[m³/h]	额定扬程 Rated head[m]	功率 Power[kW]	电压 Voltage[V]	口径 Diameter[mm]	转速 Rotational speed[r/min]
50WQD10-10-0.75	10	10	0.75	220	50	2850
50WQ10-10-0.75	10	10	0.75	380	50	2850
50WQD7-15-1.1	7	15	1.1	220	50	2850
50WQ7-15-1.1	7	15	1.1	380	50	2850
50WQD15-15-1.5(I)	15	15	1.5	220	50	2850
50WQ15-15-1.5(I)	15	15	1.5	380	50	2850
50WQD15-15-1.5	15	15	1.5	220	50	2850
50WQ15-15-1.5	15	15	1.5	380	50	2850
50WQD15-20-2.2	15	20	2.2	220	50	2850
50WQ15-20-2.2(I)	15	20	2.2	380	50	2850
50WQ15-20-2.2	15	20	2.2	380	50	2850
50WQ15-25-3	15	25	3	380	50	2850
50WQ15-32-4(I)	15	32	4	380	50	2900
50WQ15-32-4	15	32	4	380	50	2900
50WQ15-40-5.5	15	40	5.5	380	50	2900
50WQ20-40-7.5(I)	20	40	7.5	380	50	2900
50WQ20-55-11	20	55	11	380	50	2900
50WQ20-60-15	20	60	15	380	50	2900
65WQD15-6-0.75	15	6	0.75	220	65	2850
65WQ15-6-0.75	15	6	0.75	380	65	2850
65WQD20-6-1.1	20	6	1.1	220	65	2850
65WQ20-6-1.1	20	6	1.1	380	65	2850

性能曲线 Performance Curves

产品型号 Model	额定流量 Rated flow[m³/h]	额定扬程 Rated head[m]	功率 Power[kW]	电压 Voltage[V]	口径 Diameter[mm]	转速 Rotational speed[r/min]
65WQD25-7-1.5(I)	25	7	1.5	220	65	2850
65WQ25-7-1.5(I)	25	7	1.5	380	65	2850
65WQD25-7-1.5	25	7	1.5	220	65	2850
65WQ25-7-1.5	25	7	1.5	380	65	2850
65WQD25-15-2.2	25	15	2.2	220	65	2850
65WQ25-15-2.2(I)	25	15	2.2	380	65	2850
65WQ25-15-2.2	25	15	2.2	380	65	2850
65WQ25-20-3	25	20	3	380	65	2850
65WQ25-25-4(I)	25	25	4	380	65	2900
65WQ25-25-4	25	25	4	380	65	2900
65WQ30-25-5.5	30	25	5.5	380	65	2900
65WQ30-32-7.5(I)	30	32	7.5	380	65	2900
65WQ40-45-11	40	45	11	380	65	2900
65WQ40-50-15	40	50	15	380	65	2900
80WQD40-9-2.2	40	9	2.2	220	80	2850
80WQ40-9-2.2(I)	40	9	2.2	380	80	2850
80WQ40-9-2.2	40	9	2.2	380	80	2850
80WQ40-15-3	40	15	3	380	80	2850
80WQ40-18-4(I)	40	18	4	380	80	2900
80WQ40-18-4	40	18	4	380	80	2900
80WQ50-18-5.5	50	18	5.5	380	80	2900
80WQ45-22-7.5(I)	45	22	7.5	380	80	2900
80WQ70-30-11	70	30	11	380	80	2900
80WQ70-35-15	70	35	15	380	80	2900
100WQD50-7-2.2	50	7	2.2	220	100	2850
100WQ50-7-2.2	50	7	2.2	380	100	2850
100WQ50-10-3	50	10	3	380	100	2850
100WQ50-15-4(I)	50	15	4	380	100	2900
100WQ50-15-4	50	15	4	380	100	2900
100WQ80-10-5.5	80	10	5.5	380	100	2900
100WQ80-18-7.5(I)	80	18	7.5	380	100	2900
100WQ100-20-11	100	20	11	380	100	2900
100WQ100-25-15	100	25	15	380	100	2900
150WQ100-8-5.5	100	8	5.5	380	150	2900
150WQ100-10-7.5(I)	100	10	7.5	380	150	2900
150WQ150-15-11	150	15	11	380	150	2900
150WQ150-20-15	150	20	15	380	150	2900
200WQ220-8-11	220	8	11	380	200	2900
200WQ220-10-15	220	10	15	380	200	2900
100WQ100-20-11	100	20	11	380	100	1450

性能曲线 Performance Curves

产品型号 Model	额定流量 Rated flow[m <sup>3</sup> /h]	额定扬程 Rated head[m]	功率 Power[kW]	电压 Voltage[V]	口径 Diameter[mm]	转速 Rotational speed[r/min]
100WQ100-25-15	100	25	15	380	100	1450
100WQ100-30-18.5	100	30	18.5	380	100	1450
100WQ100-35-22	100	35	22	380	100	1450
100WQ100-45-30	100	45	30	380	100	1450
100WQ100-50-37	100	50	37	380	100	1450
100WQ100-55-45	100	55	45	380	100	1450
100WQ100-65-55	100	65	55	380	100	1450
150WQ180-11-11	180	11	11	380	150	1450
150WQ180-15-15	180	15	15	380	150	1450
150WQ180-18-18.5	180	18	18.5	380	150	1450
150WQ200-20-22	200	20	22	380	150	1450
150WQ180-30-30	180	30	30	380	150	1450
150WQ200-30-37	200	30	37	380	150	1450
150WQ200-35-45	200	35	45	380	150	1450
150WQ180-50-55	180	50	55	380	150	1450
150WQ200-60-75	200	30	75	380	150	1450
150WQ200-65-90	200	65	90	380	150	1450
150WQ200-75-110	200	75	110	380	150	1450
150WQ200-80-132	200	80	132	380	150	1450
200WQ250-7-11	250	7	11	380	200	1450
200WQ250-11-15	250	11	15	380	200	1450
200WQ250-15-18.5	250	15	18.5	380	200	1450
200WQ300-16-22	300	16	22	380	200	1450
200WQ250-22-30	250	22	30	380	200	1450
200WQ350-25-37	350	25	37	380	200	1450
200WQ400-25-45	400	25	45	380	200	1450
200WQ300-40-55	300	40	55	380	200	1450
200WQ400-30-55	400	30	55	380	200	1450
200WQ300-45-75	300	45	75	380	200	1450
200WQ300-55-90	300	55	90	380	1450	1450
200WQ400-55-110	400	55	110	380	200	1450
200WQ400-60-132	400	60	132	280	200	1450
250WQ500-7-18.5	500	7	18.5	380	250	1450
250WQ500-9-22	500	9	22	380	250	1450
250WQ600-9-30	600	9	30	380	250	1450
250WQ600-12-37	600	12	37	380	250	1450
250WQ600-15-45	600	15	45	380	250	1450
250WQ600-20-55	600	20	55	380	250	1450
250WQ600-25-75	600	25	75	380	250	1450
250WQ600-30-90	600	30	90	380	250	1450

性能曲线 Performance Curves

产品型号 Model	额定流量 Rated flow[m <sup>3</sup> /h]	额定扬程 Rated head[m]	功率 Power[kW]	电压 Voltage[V]	口径 Diameter[mm]	转速 Rotational speed[r/min]
250WQ600-40-110	600	40	110	380	250	1450
250WQ600-50-132	600	50	132	380	250	1450
250WQ600-60-160	600	60	160	380	250	1450
250WQ600-70-185	600	70	185	380	250	1450
250WQ750-75-200	750	75	200	380	250	1450
300WQ800-7-30	800	7	30	380	300	1450
300WQ800-9-37	800	9	37	380	300	1450
300WQ800-12-45	800	12	45	380	300	1450
300WQ800-15-55	800	15	55	380	300	1450
300WQ800-20-75	800	20	75	380	300	1450
300WQ800-25-90	800	25	90	380	300	1450
300WQ800-30-110	800	30	110	380	300	1450
300WQ800-35-132	800	35	132	380	300	1450
300WQ800-40-160	800	40	160	380	300	1450
300WQ900-40-185	900	40	185	380	300	1450
300WQ1000-45-200	1000	45	200	380	300	1450
300WQ1200-45-250	1200	45	250	380	300	1450
350WQ1000-6-37	1000	6	37	380	350	1450
350WQ1000-8-45	1000	8	45	380	350	1450
350WQ1000-10-55	1000	10	55	380	350	1450
350WQ1000-15-75	1000	15	75	380	350	1450
350WQ1000-18-90	1000	18	90	380	350	1450
350WQ1000-22-110	1000	22	110	380	350	1450
350WQ1000-28-132	1000	28	132	380	350	1450
350WQ1000-35-160	1000	35	160	380	350	1450
350WQ1100-38-185	1100	38	185	380	350	1450
350WQ1300-35-200	1300	35	200	380	350	1450
350WQ1500-36-250	1500	36	250	380	350	1450
400WQ1300-13-75	1300	13	75	380	400	1450
400WQ1300-16-90	1300	16	90	380	400	1450
400WQ1500-17-110	1500	17	110	380	400	1450
400WQ1700-16-132	1700	16	132	180	400	1450
400WQ1600-20-160	1600	20	160	380	400	1450
400WQ1600-25-185	1600	25	185	380	400	1450
400WQ1600-27-200	1600	27	200	380	400	1450
400WQ1600-30-250	1600	30	250	380	400	1450
500WQ2000-16-160	2000	16	160	380	500	1450
500WQ2200-15-185	2200	15	185	380	500	1450
500WQ2500-15-200	2500	15	200	380	500	1450
500WQ2800-15-250	2800	15	250	380	500	1450

专注专业 绿色创新 品质至上 合作共赢

## 售前 520服务

致力为客户提供高效、专业的优质体验。从收到客户咨询,5分钟内迅速响应(与客户建立沟通,了解需求),凭借团队丰富的经验和专业知识,在20分钟内给出具有建设性的方案,精准匹配客户需求,为客户的决策提供有力支持,高效专业助力业务顺利开展。

## 售中 4全服务

秉持四个“全”理念,合同全程履约,严格落实各项条款;货物全程跟踪,及时反馈物流动态;产品全程质保,确保品质无忧;服务全程放心,专业团队随时响应,为您消除后顾之忧。

## 售后 3121服务

秉持高效、负责的态度,一旦接到问题反馈,30分钟内快速响应,1小时给出排查方案,2小时初步解决,一切以客户为导向,秉持高效负责态度,持续跟进直至问题彻底解决,让客户满意。



泵与系统解决方案提供商  
PUMP AND SYSTEM SOLUTION PROVIDER

## 全心全意—客户至上

With all our heart and soul, Putting customers first

全国统一服务热线: 4008-603-757 [www.laikopump.cn](http://www.laikopump.cn)